

Corporate Ventured Technology Spin-offs: A Grounded Theory of Decision and Resource Environments

In partial fulfillment of the requirements for the Master of Engineering degree in
Telecommunications Technology Management from the Department of Systems and
Computer Engineering at Carleton University.

Steven Muegge
Carleton University
Ottawa Ontario Canada
January 2004

The undersigned recommend to the Faculty of Graduate Studies and Research
acceptance of the thesis

**Corporate Ventured Technology Spin-Offs: A
Grounded Theory of Decision and Resource
Environments**

Submitted by

**Steven Muegge
B.Eng.**

In partial fulfillment of the requirements for the degree of
Masters of Engineering

Thesis Supervisor

Chair, Department of Systems and Computer Engineering
Carleton University

Abstract

Some employees of technology corporations become entrepreneurs and found new start-up companies. This study examines the environments in which those entrepreneurs make decisions and deploy resources. Drawing from fifteen practitioner interviews and eight new venture research cases, it develops a grounded theory to account for differences in the decision and resource environments between corporate ventured technology spin-offs and independent new ventures. There are five key findings. First, two characteristics may distinguish corporate ventured technology spin-offs from other new ventures – a separation agreement with the parent firm, and a corporate incubation environment in which the venture is nurtured. Second, the spin-off is not a homogeneous phenomenon; differences in the decision and resource environments can be accounted for by considering five factors – the separation agreement, the incubation environment, the external environment, technology characteristics of the innovation to be commercialized, and financing. Third, the "start-up spin-off" is a possible mode of new venture formation that is not accounted for in published spin-off models. Fourth, corporate ventures seek legitimacy of a different sort and in different ways than do other start-ups. Fifth, to the parent corporation, a corporate incubator provides a means to mitigate corporate venturing risk. The eight research cases are new ventures founded in Ottawa Canada by former employees of Nortel Networks Corporation between 1992 and 2001.

Chapter Headings

Abstract.....	i
Chapter Headings.....	ii
Table of Contents.....	iii
Figures.....	v
Tables.....	v
1: Introduction.....	1
2: Literature Review	9
3: Theoretical Frameworks	31
4: Research Design	38
5: Analysis of Results	49
6: Discussion of Results.....	124
7: References.....	132

Table of Contents

Abstract.....	i
Chapter Headings.....	ii
Table of Contents.....	iii
Figures.....	v
Tables.....	v
1 Introduction.....	1
1.1 Research Problem.....	1
1.2 Definition of Key Terms.....	2
1.3 Methods Overview.....	3
1.4 Contribution.....	4
1.5 Summary of Key Findings.....	5
2 Literature Review.....	9
2.1 Innovation in Established Corporations.....	9
2.2 Corporate Spin-Offs.....	10
2.2.1 Terminology.....	10
2.2.2 Formation Models.....	15
2.2.3 Empirical Spin-off Studies.....	17
2.3 Corporate Venturing.....	18
2.4 A Comparison of Spin-off and Corporate Venturing Literature.....	21
2.5 Motivations of Participants.....	23
2.5.1 Founders.....	23
2.5.2 Investors.....	24
2.5.3 The Parent Firm.....	26
2.6 The Quest for Legitimacy.....	28
2.7 Business Model Discovery.....	29
3 Theoretical Frameworks.....	31
3.1 Resource Based Theory.....	32
3.2 Resource Dependence Theory.....	32
3.3 Game Theory.....	33
3.4 Organizational Ecology.....	35
3.5 Construct Development.....	36
4 Research Design.....	38
4.1 Methods.....	38
4.1.1 Preliminary Work.....	41
4.1.2 Selecting Cases.....	41
4.1.3 Instruments and Protocols.....	43
4.1.4 Entering the Field.....	44
4.1.5 Analyzing Data.....	45
4.1.6 Shaping Hypotheses.....	46
4.1.7 Enfolding Literature.....	47

4.1.8	Reaching Closure	48
5	Analysis of Results	49
5.1	Overview of Cases	49
5.2	Practitioner Beliefs.....	50
5.3	Relationships Between Categories.....	54
5.4	Core Categories.....	56
5.4.1	External Environment	57
5.4.2	Technology Characteristics.....	62
5.4.3	Financing.....	63
5.4.4	Separation Agreement.....	66
5.4.5	Incubation	70
5.5	Decision Environment	76
5.5.1	Governance	77
5.5.2	Power	82
5.5.3	Restrictions	86
5.5.4	Business Model.....	88
5.5.5	Liquidity Alternatives	90
5.5.6	Founder Motivations.....	92
5.6	Resource Environment.....	96
5.6.1	Access to Technology	97
5.6.2	Access to Capital.....	99
5.6.3	Advice	101
5.6.4	Assets and Services.....	103
5.6.5	Legitimacy	104
5.6.6	Customer Relationships	107
5.6.7	Supplier Relationships	109
5.6.8	Workforce	111
5.7	Solution to the Research Problem.....	113
5.8	Comparing Practitioner Beliefs and Grounded Theory	122
6	Discussion of Results.....	124
6.1	Validity	124
6.2	Comparison to Extant Literature.....	126
6.3	Implications for Practitioners.....	128
6.4	Opportunities for Future Research.....	129
7	References.....	132

Figures

Figure 1: Causal map (summary).....	6
Figure 2: Spin-off criteria in the management literature	12
Figure 3: The relationship between spin-off and corporate venturing research.	21
Figure 4: Research methods.....	40
Figure 5: Causal map (summary).....	55
Figure 6: External environment groups	57
Figure 7: Growth model of a VC-backed new venture.....	64
Figure 8: Separation agreements of case study ventures	68
Figure 9: Growth model of a spin-off from a corporate incubator.	71
Figure 10: Growth model of a "start-up spin-off" – an external corporate ventured spin-off	72
Figure 11: Orthogonality of the separation agreement and incubation categories	74
Figure 12: Factors influencing the decision environment.....	76
Figure 13: Causal map of selected governance properties.....	81
Figure 14: Factors influencing the resource environment	96
Figure 15: Operational data structure characterizing a new venture	115

Tables

Table 1: Examples of spin-off definitions in the management literature, arranged from most inclusive to most restrictive.	13
Table 2: The external environment.....	58
Table 3: Expanded tabular display of governance properties.....	79
Table 4: Relationships between categories (cause and effect).....	117
Table 5: Emergent hypotheses.....	118

1 Introduction

Some employees of technology corporations become entrepreneurs and found new start-up companies (Moore & Davis, 2000; Saxenian, 1994). Most entrepreneurs resign from their corporate employer and seek outside financing to grow their business (Nesheim, 2000). Though in the minority, some entrepreneurs are supported by their corporate employer, which may participate in the new venture in pursuit of strategic or financial returns (Block & MacMillan, 1993).

Corporate ventured technology spin-offs may face very different initial conditions than those faced by independent start-ups. The parent corporation may provide financing, contribute assets, share resources, and possibly incubate the venture until it can secure outside financing or bootstrap its growth from its own revenue. In exchange, the parent may take an ownership position and a governance role in the new venture. These differences would be expected to impact the environment for decision-making and the resource environment of the new venture.

Past studies have typically approached the corporate ventured technology spin-off from one of two perspectives – corporate spin-offs or corporate venturing. This inductive study develops a grounded theory to account for differences in the decision and resource environments of new ventures at the intersection of both research streams. The model and its implications are of interest to researchers and practitioners seeking to understand the dynamics of new venture creation, including entrepreneurs, investors, corporate executives, and public policy-makers.

1.1 Research Problem

Develop a theory to account for differences in the decision and resource environments between corporate ventured technology spin-offs and other start-ups.
--

The solution is a grounded theory of new venture decision and resource environments, summarized in section 1.5, and detailed in section 5.7.

1.2 Definition of Key Terms

For the purposes of this study, a *corporate ventured technology spin-off* is a new venture that was derived from a parent corporation, where "derived from" is defined by the following three criteria:

- The new venture was founded by former employees of the parent corporation
- The new venture sought to commercialize a technology developed or pursued by the parent corporation
- The new venture was supported by the parent corporation through a corporate venturing arrangement that provided the new venture with access to intellectual property.

This definition avoids the confusion in the management literature regarding the specific usage of the terms *corporate spin-off* and *corporate venturing* (discussed in sections 2.2, 2.3 and 2.4). It is intended to be broadly inclusive to encompass some new ventures that would have been excluded from past spin-off studies. The parent corporation may or may not internally incubate the new venture, retain some equity ownership, or take a governance role in the new venture; these corporate policy decisions are not criteria for inclusion in the above definition.

This study introduces two new theoretical constructs – the *decision environment* and the *resource environment* (developed in section 3).

The *decision environment* is the totality of circumstances and conditions that surround the decision-making entrepreneur. It includes the scope of possible decisions, the set of all possible courses of action (for example, the possible solutions to a specific problem), and various factors that could influence the decision-making entrepreneur. It does not describe how a particular decision-making entrepreneur arrives at a particular decision; rather it characterizes the environment in which an entrepreneur makes decisions, irrespective of their particular evaluation criteria and decision-making process.

The *resource environment* is the set of all possible resources that an entrepreneur has available, including money, time, people, reputation, support (technical, managerial, psychological), and established relationships (customers, suppliers, investors, key talent). The

decision-making entrepreneur employs these resources to assist with decision-making, and deploys these resources to execute their decisions.

The terminology of these constructs was inspired by Goel & Pirolli's (1992) cognitive science work on the structure of design problem spaces. In their analysis framework, they employ the notion of a *task environment*, derived from Newell & Simon's (1972) information-processing theory of human problem solving. Entrepreneurism shares many qualities with design; it is an ill-structured problem, with tasks involving underspecified goals and operators, and requiring logical and creative elements.

The elements comprising the decision and resource environments were developed from stakeholder analysis, then further refined inductively from case study data and interviews with practitioners.

1.3 Methods Overview

The research design was *multiple case study* (Yin, 1989) using *grounded theory* logic (Glaser & Strauss, 1967) and *qualitative cross-case analysis* (Miles & Huberman, 1994). The theory-building methods here were similar to those recommended by Eisenhardt (1989), and employed by Brown & Eisenhardt (1997) and Bessant (1998) for exploratory studies of other management phenomena.

The unit of analysis was the entrepreneurial new venture. Eight cases were developed and examined as independent experiments that confirmed or disconfirmed emerging conceptual insights (Yin, 1989). The primary data was semi-structured interviews with individual respondents. The set included both the *founder* and *investor* perspectives on most cases. Interviews included *open-ended questions* to initiate stories, and *probing questions* to establish details, conducted according to accepted interviewing best practices (Foddy, 1993). Secondary data sources included corporate websites, press releases, quarterly and annual financial reports, independent analyst reports, and media coverage. *Stakeholder analysis* (Smi, 2000) was employed to identify possible lines of inquiry and develop preliminary a priori constructs of the decision and resource environments. These lines of inquiry were tested at interviews with practitioners familiar with start-up and spin-off firms. The elements comprising the decision and resource environment constructs were continuously refined throughout the study.

The underlying logic of this research was *grounded theory building* from field-based case data. As established by Glaser & Strauss (1967), grounded theory is appropriate for investigating rarely explored phenomena for which extant theory is not applicable. In such situations, an exploratory grounded theory-building approach is more likely to generate novel and accurate insights into the phenomenon under study than is reliance on either past research or office-bound thought experiments. The standard grounded theory procedures developed for participant observation in the social sciences (Strauss & Corbin, 1990) were adapted here to address differences in the form of theory and the nature of the data of management research (Eisenhardt, 1989; Partington, 2000). Less-structured emergent methods (Glaser, 1978, 1992, 1998) were favored over proceduralized methods (Strauss & Corbin, 1990). The emergent theory enfolds extant literature as appropriate.

1.4 Contribution

Christensen, Carlile & Sundahl (2002) issue a call for more high-impact management research that builds useful management theory – specifically the design of more studies to actively seek out and observe anomalies with existing theory, the development of robust categorization frameworks that account for both new phenomena and the results of prior research, and more research effort to examine theory through the lenses of other disciplines. This study responds to that call as follows:

- It examines the phenomena of corporate ventured technology spin-offs through the lenses of two different research perspectives, that of corporate spin-offs and corporate venturing. Past research has adopted either perspective, but not both.
- It complements prior and ongoing research by utilizing different methods. This study employs inductive logic on a small sample of detailed case studies. Past research has typically employed deductive logic on larger samples of firms.
- It examines a new data set – new ventures in the Ottawa technology cluster founded by former employees of Nortel Networks. Past research has focused on American, European, or Asian regions, which may have different regional, legal, and cultural characteristics.

This study contributes to management practice by providing entrepreneurs, venture capital investors, and corporate executives with a predictive theory to understand how their actions will impact decision-making and resourcing of a new venture.

This study makes three contributes to the management literature as follows:

- It introduces two new and useful theoretical constructs – the decision and resource environments – and develops their component elements.
- It develops a grounded theory to account for differences in the decision and resource environments of corporate ventured technology spin-offs and other new ventures, mapping each element back its influencing factors.
- It compares emergent findings with extant literature to extend or replicate existing theory, identify anomalies with past research, and propose areas for new research.

1.5 Summary of Key Findings

This work has resulted in five key finding.

1. **Corporate ventured technology spin-offs have a *separation agreement* with the parent firm, and may be nurtured in a corporate *incubation* environment.** These two characteristics differentiate corporate ventured technology spin-offs from other new ventures.
2. **The spin-off is not a homogeneous phenomenon.** The attributes of spin-offs can vary widely. Differences in the decision and resource environments can be accounted for by considering five factors – the *external environment*, *technology characteristics*, *financing*, the *separation agreement*, and the *incubation environment*.
3. **The "start-up spin-off" is a possible mode of new venture formation.** New ventures which spin-off from the parent, then subsequently negotiate an agreement for access to parent-controlled technology operate in different decision and resource environments than either independent start-ups or ventures in a corporate incubator. This category is not accounted for in published spin-off models.

4. **Corporate ventures seek legitimacy of a different sort and in different ways than do other start-ups.** Entrepreneurship research has shown that new ventures initially have low legitimacy in the marketplace. The corporate ventured technology spin-offs in this study initially appeared more legitimate to the outside world. However, some founders struggled to acquire entrepreneurial legitimacy within the parent corporation.
5. **Corporate incubators provide the parent corporation with a means to manage corporate venturing risk.** This function of corporate incubators is in addition to the other two functions widely documented in the management literature – that of improving the likelihood of new venture success, and encouraging entrepreneurially-minded employees to develop their new business ideas within the corporation rather than independently.

These findings receive expanded treatment in section 6.

Figure 1 illustrates the high-level relationships between variables as a simplified causal map. This is a summary of the solution to the research problem posed in section 1.1. The full grounded theory is summarized in section 5.7.

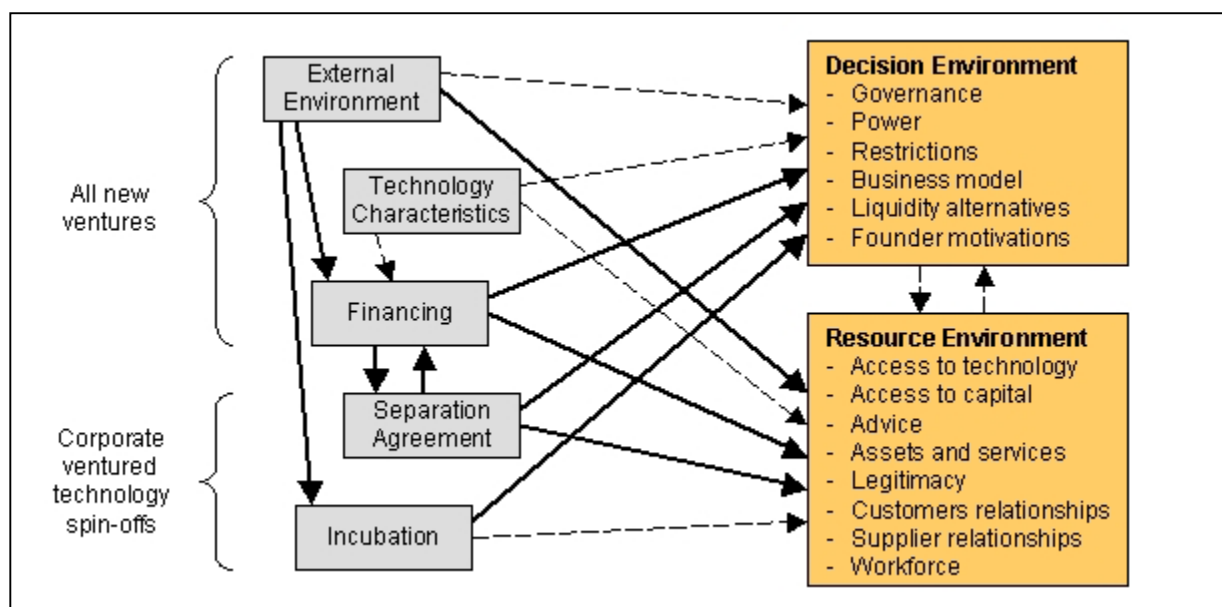

Figure 1: Causal map (summary)

The *decision environment* is the totality of circumstances and conditions that surround the decision-making entrepreneur to determine the scope of possible decisions, the set of all possible courses of action, and various factors that could influence the outcome of a decision. The elements of the decision environment are *governance, power, restrictions on behavior, business model discovery, liquidity alternatives, and founder motivations*. The *resource environment* is the set of all possible resources that a decision-making entrepreneur can employ to help make decisions and deploy to execute on decisions. The elements of the resource environment include access to *access to technology, access to capital, advice, assets and services, legitimacy, customer relationships, supplier relationships, and the workforce*.

The *separation agreement* describes the legal relationship between the new venture and the parent corporation, which may include parent ownership and licensing agreements. It impacts a new venture's governance, restrictions on behavior, liquidity alternatives, founder motivations, access to technology, access to advice, legitimacy, customer relationships, supplier relationships, and the characteristics of the workforce.

The *incubation environment* describes the climate in which the new venture is nurtured. It impacts a new venture's governance, distribution of power, restrictions on behavior, and access to certain assets and services.

The *external environment* describes factors external to the new venture over which the founding entrepreneurs have no control, including market conditions, regional conditions, and conditions at the parent corporation. It impacts a new venture's ability to raise financing, the availability of corporate incubation, liquidity alternatives, founder motivations, access to capital, access to advice, legitimacy, customer relationships, supplier relationships, and the characteristics of the workforce.

Technology characteristics describe the innovation that the new venture seeks to commercialize. A particular innovation could be disruptive or sustaining. It could be resource-intensive or have a low demand for resources. These characteristics impact a new venture's ability to raise financing, the process of business model discovery, access to capital, legitimacy, and supplier relationships.

Financing describes the source of capital to fuel the growth of the new venture. It impacts a new venture's separation agreement, governance, distribution of power, process of business model discovery, access to capital, access to advice, legitimacy, customer relationships, and supplier relationships.

2 Literature Review

This section reviews the salient management literature on the following topics:

- corporate innovation
- corporate spin-offs
- corporate venturing
- motivations of participants in spin-offs and corporate venturing (founders, parent corporations, venture capital investors)
- legitimacy
- business model discovery

Grounded method theorists (Glaser & Strauss, 1967; Glaser, 1978, 1992, 1998) warn researchers against forcing the data to fit preconceived conclusions. Special care was taken to heed Dick's (2000) advice to access the literature only *as it becomes relevant*. For example, recent dissertations such as Lindholm (1994), Parhankangas (1999), and Tübke (2001) were accessed only in the late stages of data analysis and documentation. The topics of emergence, forcing, and the place of literature in a grounded theory study are discussed extensively in the Methods chapter (section 4.1).

2.1 Innovation in Established Corporations

A large body of research suggests that experience can become a liability in the face of radical change (Abernathy, Clark & Kantrow, 1983). Established firms can have great difficulty managing innovations that fall outside of their previous experience, including competency-destroying innovations (Tushman & Anderson, 1986), architectural innovations (Henderson & Clark, 1990), and disruptive technology that changes the basis for competition in an industry (Rosenbloom & Christensen, 1994). According to Christensen (1997), managers within established firms focus resources on their current markets and customers that made them successful, overlooking future markets which are unknown and fundamentally unknowable. Thus established firms are effective and far-sighted when the technological opportunity reinforces the firm's current business, but ineffective and myopic when that opportunity disrupts the firm's current business.

The notion of *cognitive bias* suggests that it may well be human nature to repeat the behaviors that resulted in past successes. Experienced managers tend to follow *established routines* (Nelson & Winter, 1982) and exhibit *knowledge biases* (Wright, 1997). Organizations are bound in *structural inertia* (Hannan & Freeman, 1989) and have a limited *absorptive capacity* to recognize the value of a new venture; absorptive capacity is largely as a function of an organization's prior knowledge (Cohen & Levinthal, 1990). Prahalad & Bettis (1986) describe *dominant logic* as a set of heuristic rules, norms and beliefs that managers create to guide their actions; this logic implicitly filters out ideas and behaviors that do not comply. Chesbrough & Rosenbloom (2002) regard the difficulty of managers to manage innovations outside of their previous experience as a symptom of a larger cognitive failure – an inability to perceive alternative paths that would span the domains and enable realization of greater economic reward.

A related body of research (Tushman & O'Reilly, 1997; Hamel, 1999, 2000; Leifer et al., 2001) acknowledges the apparent limitations of established firms, but suggests that these limitations may be at least partially overcome. Nonetheless, new ventures would appear to have some natural advantages at realizing some innovations.

2.2 Corporate Spin-Offs

Despite growing attention from researchers, the phenomenon of corporate spin-offs is not well understood. Even the usage of basic terminology, such as the definition of a spin-off, varies widely. This section reviews the literature on spin-off terminology, spin-off formation models, and the results of empirical spin-off studies.

2.2.1 Terminology

The term "spin-off" (or alternately "spin-out") is common within the parlance of researchers and management practitioners. However, there is significant confusion regarding its specific usage, and different experts on entrepreneurship employ the term in similar but incongruent ways. Some experts reserve the term exclusively for planned ventures that are supported by a parent corporation, while some other experts employ the term very broadly to encompass all new ventures that can trace some aspect of their origins to another organization. Other experts employ a variety of defining criteria that form spectrum between these two

extremes.

The Merriam-Webster dictionary provides the following definitions:

Spin-off: *n.* **1** the distribution by a business to its stockholders of particular assets and especially of stock of another company; *also* : the new company created by such a distribution. **2** a collateral or derived product or effect, by-product; *also* a number of such products <the *spin-off* from the space program>. **3** something that is imitative or derivative of an earlier work; *especially* : a television show starring a character popular in a secondary role of an earlier show.

The second and third definitions are relevant for the purposes of this study – a *spin-off* is a by-product derived from an earlier work. Thus, in general, a *corporate spin-off* is a business venture that is derived from an established corporation. (Despite the usage of business terms, the first definition is of a specific financial operation that is unrelated to entrepreneurship.)

Researchers and practitioners disagree on the specific operational criteria of what it means to be derived from an established corporation. Published studies typically cite one or more of the following three sorts of criteria in defining a corporate spin-off:

- **People (P):** One or more founding entrepreneurs leave the parent organization to join the new venture.
- **Technology (T):** The underlying technology commercialized by the new venture originated at the parent corporation.
- **Asset Transfer (A):** There was a formal legal transfer of assets from the parent to the new venture. The transferred assets may include intellectual property and physical property.

In principle, there are numerous ways to combine these criteria, particularly when considering not only intersections of sets (i.e. a spin-off must have people AND technology from the parent) but also unions of sets (i.e. a spin-off could have either people OR technology from the parent). In practice, the criteria tend to be combined such that the set of spin-offs is either broadly inclusive or very restrictive, as shown in Figure 2.

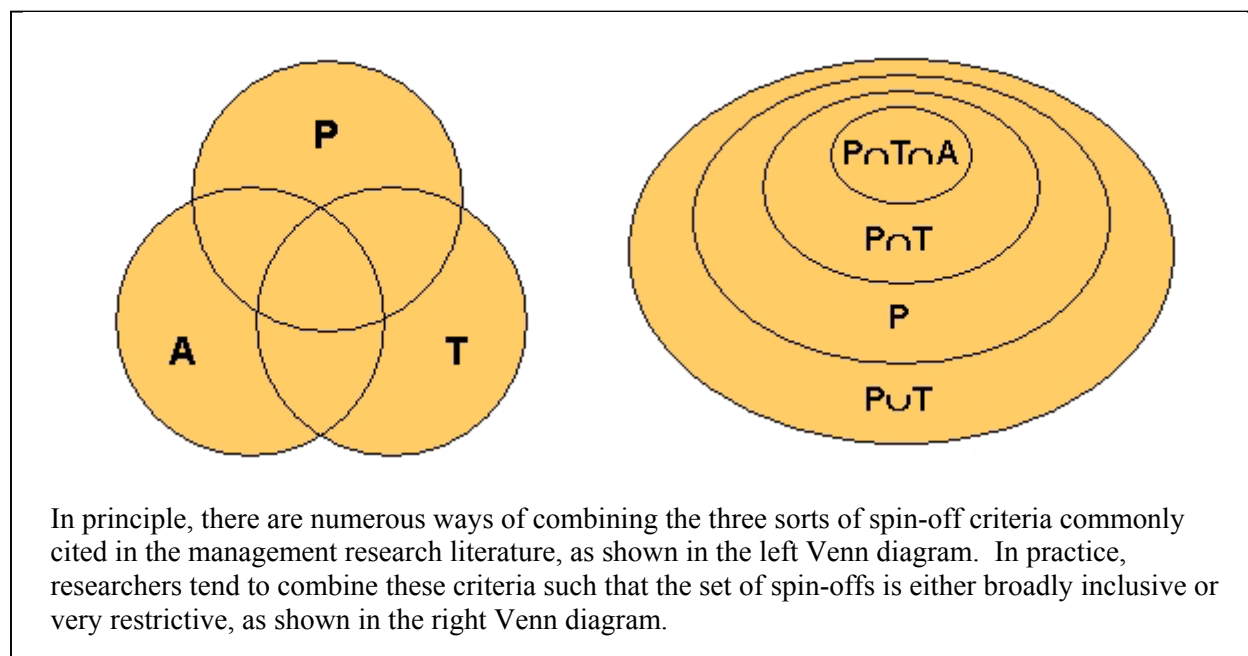

Figure 2: Spin-off criteria in the management literature

Table 1 provides examples of how a selection of past spin-off studies have defined their unit of analysis. The first column indicates which general criteria are employed, where P indicates people, T indicates technology, and A indicates formal asset transfer. Depending on the definition employed in a particular study, one, two or all three of the following new venture scenarios may be classified as spin-offs:

- a) A team of employees resign together to found a new venture.
- b) A team of employees found a new venture to commercialize a technology from the parent corporation. The technology was not protected intellectual property, either because the parent was unwilling or unable to defend it. The technology could have been placed in the public domain (perhaps through standards activity), or perhaps the regional legal climate is not supportive of IP disputes (as is common in Silicon Valley).
- c) A parent corporation seeks to commercialize a technology that is potentially lucrative, but not aligned with its strategic direction and core competencies. It does so by intentionally

nurturing and supporting the creation of a new venture. It provides starting capital, incubates the new venture as an internal business unit, helps it secure external financing, and spins it off as a separate company, retaining for itself majority control.

The three right-most columns of Table 1 show which of the above scenarios would be included in that study's definition of "spin-off". An 'X' indicates that the scenario would be included within that study's definition of spin-off. An 'O' indicates that the study imposes additional criteria that may or may not include that scenario. These scenarios are provided as examples to illustrate the divergence in the inclusiveness of different published criteria. As shown in sections 2.5.1 to 2.5.3, this list of spin-off scenarios is far from exhaustive.

Table 1: Examples of spin-off definitions in the management literature, arranged from most inclusive to most restrictive.

Criteria	Reference	Definition	a)	b)	c)
$P \cup T$	Doyle (2002)	The main criterion for source identification is the premise that the company would not have been formed if the technology or the people had not been involved at that time.	X	X	X
P	Klepper & Sleeper (2002)	A new entrant founded by employees of firms in the same industry.	X	X	X
	Agarwal et al. (2002)	An entrepreneurial venture by an ex-employee.	X	X	X
	Franco & Filson (2000)	A firm started by a former employee of an incumbent firm.	X	X	X
	Dyck (1997)	An organization founded by two or more persons who had previously worked together at the parent.	O	X	X
$P \cap T$	Anton & Yao (1995)	An employee discovers a significant invention and negotiates a contractual organizational arrangement with the employer to develop the invention.		O	X
	Chesbrough & Smith (2000)	The technology involved was initiated or pursued for at least one year at the parent; at least one researcher left to become an employee of the new spin-out; the spin-out and researcher were incorporated into a new legal entity.		O	X
$P \cap T \cap A$	Lindholm Dahlstrand (2001)	An entrepreneur leaves an organization to start a business of his/her own. This must include the transfer of some rights, e.g. assets or knowledge, from the existing legal body to the new firm.			X

The definition of corporate ventured technology spin-off employed in this study is discussed in sections 1.2 and 2.4.

Some recent European studies have adopted a broadly inclusive perspective on the spin-off phenomenon, and proposed various classification frameworks. Lindholm (1994) recommends classifying corporate spin-off firms in terms of the type of transfer of ownership rights from a parent firm to its spin-off. In a *divestment* spin-off, the majority of the voting power is transferred from an existing legal entity to a new body or to another firm. In an *entrepreneurial* spin-off, there is usually no formal transfer of ownership rights. Most typically, an entrepreneurial spin-off occurs when an entrepreneur leaves his previous employment to start a firm of his own.

Tübke (2003) defines the spin-off process as the division of one company into two companies, where the larger company would be called the parent, and smaller company would be called the spin-off. He divides the process into three phases – the *decision phase* (including all factors leading to the decision to spin-off), the *separation phase* (comprising the strategic and organizational separation of the two companies), and the *post-separation phase* (that starts with the independent operation of the parent and spin-off and ends when no more preferential agreements or relations between parent and spin-off exist. Based on a literature survey of 81 scientific articles and books, Tübke, Álvarez de Toledo-Saavedra, & Galán-González (2003) propose a typology of spin-off definitions including four main types, twelve sub-types, and seven complementary characteristics. The typology has five classification criteria – *originating organization* (corporate or institutional), *main motivation* (restructuring or entrepreneurial), the nature of the *spin-off process* (formal or informal), *control* (internal, latent, or external), and *consent* (friendly or hostile). From the same literature survey, Tübke, et al. (2003) also compiles a list of twenty-one factors influencing the spin-off decision, and a second list of twenty-one success factors impacting spin-off performance. Ten factors are common to both lists.

Parhankangas & Arenius (2003) propose a taxonomy of corporate spin-off firms by exploring the parent firm – spin-off firm relationship, particularly complementarity, intensity of collaboration, and dependency on resources. The three categories derived from cluster analysis of Finnish firms are *spin-offs developing new technology*, *spin-offs developing new markets*, and

restructuring spin-offs. Firms in each category exhibited similar characteristics at formation, spin-off, and post-spin-out.

Klepper's (2001) classification of spin-off formation models, discussed below, could also be treated as a spin-off categorization framework. This is discussed in the following section.

The related body of management research on *university spin-offs* is not reviewed here. A university spin-off is a new business venture that was derived from an academic research program (Roberts, 1991; Lindholm, 1994; Autio, 1997; Shane & Stuart, 2002).

2.2.2 Formation Models

Klepper (2001) surveys the existing management literature on spin-off formation (from a genealogy or corporate lineage perspective) and classifies the formation theories into four theoretical perspectives – *agency theories*, *organization capability theories*, *employee learning theories*, and *heritage theories*. Klepper also proposes a new fifth perspective – an *evolutionary model*. Klepper explores the implications of the various formation theories according to the nature of the spin-off, the kinds of firms that are parents of spin-offs, the timing of the spin-offs, and the performance of the spin-offs. Each perspective is briefly summarized below using Klepper's classifications, including some additional references published after Klepper's survey.

The *agency theory perspective* models spin-offs that are formed to capitalize on an employee's discovery made during employment at the parent firm. Due to various agency costs and asymmetric information, the employee elects to leave his employer to form an independent new entrant rather than develop the invention within the established firm. Some agency models include contracting with the parent to form a new entrant (perhaps a planned equity spin-off) as a third option. Wiggins (1995), Anton & Yao (1995), Bankman & Gilson (1999), and Hellmann (2003) each model this situation to predict the circumstances under which the employee is more likely to make a particular choice. Hellmann's model, for example, predicts that the rate at which employees become entrepreneurs depends on corporate strategy, the entrepreneurial environment, and the intellectual property regime. These models imply that spin-offs would develop innovations their parents may also be interested in pursuing.

The *organizational capability perspective* models spin-offs formed to exploit innovations

that the parent would be slow to pursue because of organization limitations that challenge incumbent capabilities. Possible limitations include organizational crisis (Cooper, 1985, Brittain & Freeman, 1986), competence-destroying innovations (Tushman & Anderson, 1986), architectural innovations (Henderson & Clark, 1990), disruptive technological innovations (Christensen, 1997), or innovations that cannot be defined in a standard business plan (Bhide, 2002). These theories imply that spin-offs will pursue particular types of innovations that their parents would have difficulty developing, and thus would be unlikely to pursue.

The *employee learning perspective* views spin-offs as exploiting knowledge that their founders learned in their prior employment to compete against the parent. Franco & Filson (2000), and Klepper & Sleeper (2002) each propose detailed learning models of spin-offs that inherit knowledge from their parents that shapes their nature at birth. These theories imply that spin-offs will pursue the same overall strategy as their parents. The Franco & Filson (2000) model predicts that more technologically advanced firms will produce spin-offs, that firms with higher technological know-how will survive in the following period with a higher probability than those with lower technological know-how, and a spin-off's probability of survival into its second period depends on the know-how of its parent. The Klepper & Sleeper (2002) model predicts that laser industry spin-offs will initially service smaller niche markets, produce a similar product to their parents (which will continue to produce that product), are more likely to spawn from parents with a broad product portfolio, and are more likely to spawn from longer-lived parents.

The *heritage perspective* conceptualizes organizations as members of extended families using a biological metaphor. By treating spin-offs as children of parent firm, it attempts to apply the learnings from human family research to the study of organizations. From interview data, Dyck (1997) proposes a grounded typology of *planned*, *unwanted*, *adopted*, and *orphan* spin-offs. Dyck (2001) extends this notion to consider broader organizational clans that may span several generations. Just as parental involvement and support is generally helpful to children, planned spin-offs are expected to outperform unplanned ones.

From the perspective of the Christensen et al. (2002) theory-building model, Klepper's classification of theoretical perspectives could also be treated as an attribute-based classification

scheme of spin-offs. For example, a new venture would be termed an agency spin-off if the agency theory perspective successfully predicted the characteristics of that venture.

2.2.3 Empirical Spin-off Studies

Several recent studies have provided comprehensive surveys of new entrants across a particular industry, geographic region, or parent firm. Cooper (1971) examines approximately 250 new entrants in Silicon Valley in the 1960s, covering all known start-ups from that region and time period. Brittain & Freeman (1986) examine all lineage spin-offs of Silicon Valley semiconductor producers in 1955-1981. Boeker (1988) examines a sample of 51 semiconductor firms in Silicon Valley, 45 of which were lineage spin-offs. Roberts (1991) examines the technology spin-offs of MIT. Christensen (1993, 1997) examines the comprehensive evolution of the hard disk drive industry from its inception through 1989. Franco & Filson (2000) examine all 192 U.S. commercial disk drive producers in 1977-1997 and identify 40 firms as lineage spin-offs. They observe that firm size is not significantly correlated with the probability of spin-off generation. Agarwal, Echambadi, Franco, & Sarkar (2002) re-examine this data to explore the notion of a parent and progeny knowledge transfer relationship. They show that the parent knowledge capabilities at the time of spin-off founding are positively correlated to the spin-offs knowledge capabilities and its probability of success. Working from a technology perspective, Chesbrough & Smith (2000) examine each of the 35 firms that spun out of Xerox from 1979 to 1998. They argue that most of the technologies did not initially have obvious value, but spin-offs that were controlled by outside investors were more likely to attempt a transformation of the technology and business model that resulted in evident value. Klepper & Sleeper (2002) examine all lasers entrants from the start of the industry in 1961 through to 1994, tracing the lineage of each producer, and identifying 79 of the 193 de novo entrants as spin-offs.. They found that spin-offs exploit knowledge their founders acquire from their parent employers, and propose that spin-offs are more likely when quantity and quality of this information is higher. Second, spin-offs pursue ideas involving new niche markets or technologies their parents are unwilling or slow to pursue, and thus propose that conditions favorable to the creation of niche markets are thus conducive to spin-offs. Third, spin-offs are a distinctive form of entry that is not responsive to market conditions in the same way as other kinds of entry.

Other studies have employed some form of sampling. Walsh, Kirchhoff & Boylan (1996) examines a sample of 35 new entrants in the semiconductor silicon industry and analyzes performance factors. Chesbrough & Rosenbloom (2002) select six of the spin-offs from Chesbrough & Smith (2000) for more detailed case study, and conclude that significant transformations occurred in the business models of successful spin-offs, while search and learning in failed ventures were quite limited.

2.3 Corporate Venturing

Corporate venturing (CV) broadly includes all corporate activity in new ventures, including a spectrum of strategies of varying levels of involvement. Roberts' (1980) early study of CV strategies includes corporate venture capital (CVC, directly investing corporate funds in external start-ups), venture nurturing (adding managerial assistance in such areas as marketing, manufacturing, and research), venture spin-offs, new-style joint ventures, venture merging and melding, and internal ventures, with no particular method being dominant. Roberts proposes three generalizations on corporate venturing strategy. First, CV requires long-term persistence. Second, CV depends on entrepreneurial behavior. Third, no single strategy works for all.

The popularity of corporate venturing appears to rise and fall in approximately ten-year cycles with the venture capital industry and the broader equity markets (Block & MacMillan, 1993). Activity peaked in the late 1960s (Fast, 1978), mid-1980s (Yost, 1994), and late 1990s, declining again each time at the next market downturn (Chesbrough, 2000). Corporate venturing programs established during the 1990s included Xerox Technology Ventures (Hunt & Lerner, 1995; Chesbrough & Smith, 2000; Chesbrough & Rosenbloom, 2002), the Lucent New Ventures Group (Chesbrough & Socolof, 2000), and the Nortel Networks Business Ventures Program (Colarelli O'Connor & Maslyn, 2002; Leifer et al., 2001). At the time of this writing, corporate venturing has again fallen from favor in the high-tech industry. Nonetheless, some researchers and consultants advocate corporate venturing as a possible source of sustained competitive advantage for established corporations (Mason & Rohner, 2001; Richards, 2001; Hyland, 2002).

Corporate venturing can provide favorable financial returns when compared to the returns from independent venture funds. During its eight-year lifetime, the \$30M XTV fund invested in over twelve ventures, delivering capital gains of \$219M. Hunt & Lerner (1995) estimate that

\$175 returned to Xerox, suggesting a 56% internal rate of return compared to a mean net return of 13.7% by independent VC funds over the same time period. Nonetheless, the program was discontinued, underscoring the significant challenges of fostering entrepreneurship within large corporations.

Chesbrough's (2000) survey of corporate venturing literature identifies several specific challenges that those initiatives face, including *adverse selection*, *resource allocation conflicts*, *conflicts of interest* between the new venture and the parent sponsor, and potential *conflict of objectives* between financial and strategic objectives. Von Hippel (1977) identified the problem of *adverse selection*. Over time, the best performing ventures either spin-off or migrate to other divisions, leaving the corporate venturing organization with the under performing ventures. Fast (1978) noted that managers of established businesses can view successful corporate ventures as threats which compete for scarce resources. Rind (1981) explored possible *conflicts of interest* within new venture organizations between the success of the parent sponsor and the success of the new venture. The sponsor may constrain the marketing options of the new venture in order to prevent competition with existing businesses. Siegel, Siegel & MacMillan (1988) explored the potential conflict between two frequently cited rationales for new venture businesses. *Strategic* investments seek to exploit the potential for additional growth latent in the parent sponsor – in other words, improve the performance of existing businesses. *Financial* investments aim to create additional revenue and profit in the new venture itself. According to Siegel, et al, parental intervention to align the venture with strategic interests reduces the autonomy of the new venture, and likely reduces financial performance.

Chesbrough (2000) proposes that corporate venture structures and venture capital structures have some significant differences. Compared to venture capital, corporate venturing provides weaker incentives for success, weaker financial discipline on the downside (i.e. slower to terminate under performing ventures), internal (rather than external) monitoring, and constrains the discovery of alternative business models (Chesbrough & Rosenbloom, 2002). Potential advantages include longer investment time horizons (unconstrained by the fixed lifetime of a VC fund), larger scale of capital investment, management of strategic complementarities, and the retention of group learning. Chesbrough argues that for corporate

venturing to succeed and persist through the less exuberant market cycles, it must leverage these potential advantages to deliver strategic benefits to the sponsoring firm.

Von Hippel (1977) showed that corporate ventures were more likely to succeed when the parent firm had significant prior experience in the target market. Experience with the technology, however, did not correlate to increased likelihood of success. Athey & Stern (1997) introduced *complementarity* – the notion that corporations can benefit from closely related activities. Research suggests that intrapreneurship and CVC programs are both more effective when investing in businesses that are closely related to the core competencies of parent. In a comparison of VC and CVC investments, Gompers & Lerner (1999b) found that corporations may be able to select better ventures using information from their related businesses and provide greater value to those firms once the investments are made. CVC programs without a well-defined strategic focus have less investment success and less stability than well-defined programs. Likewise, the successful investments of the Xerox Technology Ventures program were concentrated in industries closely related to corporate parent's business (Hunt & Lerner, 1995).

According to Mason & Rohner (2002), the values of a corporation are diametrically opposed to those required to start a successful new business. A corporate venture must negotiate with corporate interests, cope with a slow decision process, juggle conflicting priorities, and battle an internal environment that encourages everyone to mitigate risk constantly. They describe this struggle as *battling corporate antibodies*, and propose the following possible areas of tension:

- Talent: A new venture may compete with the parent for key talent. The parent may seek to install seasoned executives with the wrong experience and outlook (for example, adherence to tradition and aversion to risk).
- Roles: Strategy and execution at a new venture are closely coupled, therefore senior management must be very hand-on. The best managers at corporations are not necessarily the best people to start a new venture.
- Risk: Uncertainty is a normal managed risk for a new venture. Corporations are slow to change direction, and thus require more analysis and planning to reduce uncertainty.

- Rules: New ventures need to execute and adapt quickly, and may be straight jacketed by corporate rules and processes to reduce risk.
- Performance: New ventures are highly vulnerable to volatile demand and large swings of a small customer base. Quarterly results are unpredictable and uneven.
- Cannibalization: The new venture may compete with the parent, or expose the parent's established customer base to unproven products and services.
- Brand: The parent may be reluctant to endanger a brand that cost massive investment in time to money.
- Failure: In the venture community, failure is viewed as a stepping stone to success. In the corporate world, even one failure can stall a career.

2.4 A Comparison of Spin-off and Corporate Venturing Literature

There is significant overlap in scope between spin-off research and corporate venturing research (see Figure 3). Corporate ventured technology spin-offs, as defined in section 1.2, exist within this intersection.

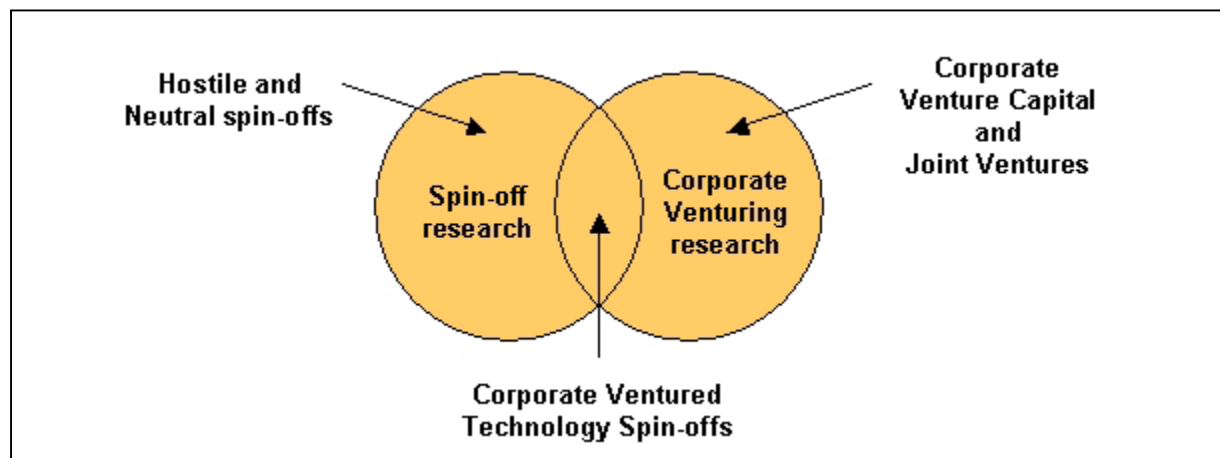

Figure 3: The relationship between spin-off and corporate venturing research.

Spin-off research tends to examine aggregate properties of new ventures across a particular industry or region. Corporate venturing research tends to investigate investment decisions from the perspective of the parent corporation. Neither research stream seeks to address the primary concerns of the entrepreneurs who found the new venture.

This study adopts a pragmatic approach to defining its unit of analysis. Starting from a broadly inclusive perspective on corporate spin-offs, it then applies additional criteria of technology and corporate venturing. To move past the confusion regarding the specific usage of terminology, it introduces the following new operational definition.

A corporate ventured technology spin-off is a new venture that was derived from a parent corporation, where "derived from" is defined by the following three criteria:

- The new venture was founded by former employees of the parent corporation
- The new venture sought to commercialize a technology developed or pursued by the parent corporation
- The new venture was supported by the parent corporation through a corporate venturing arrangement that provided the new venture with access to intellectual property.

The attributes of the corporate venturing relationship could vary widely. For example, the parent corporation may or may not internally incubate the new venture, retain some equity ownership, or take a governance role in the new venture; these corporate policy decisions are not criteria for inclusion. This definition includes, for example, majority-controlled ventures that would be excluded by Lindholm's (1994) requirement of the transfer of majority voting control.

This definition was deemed sufficiently robust to classify the new ventures in the study data set and provide a starting point for further investigation. It is intentionally a somewhat "fuzzy set", and could be problematic for classifying marginal cases. It does not, for example, bound the number of founders from the parent (One? More than half? All?) or the particular role of the intellectual property in the new venture. Rather than impose additional and perhaps artificial scope constraints on the process of emergent discovery, this study employed theoretical sampling to select appropriate cases.

2.5 Motivations of Participants

This section considers the motivations of the three main participants in the formation of corporate ventured technology spin-offs. In particular, it explores possible answers to the following three questions:

1. Why would an entrepreneur want to form a spin-off?
2. Why would an outside investor choose to invest in a spin-off?
3. Why would an established corporation want to allow or even encourage the formation of a spin-off?

Insights from the management literature regarding the possible motivations of each party are explored below.

2.5.1 Founders

Spin-off founders could be motivated by the same factors cited by other entrepreneurs (Cooper, 1986; Stanworth, Stanworth, Granger & Blyth, 1989; Roberts, 1991; Bhide, 2000), such as wealth creation, independence, prestige, power, and the personal sense of achievement from creating something new. One practitioner in this study described entrepreneurial drive as "a fire in the belly". Why then, would an entrepreneur create a spin-off rather than an independent new venture?

Garvin (1983) found that employees who leave to start their own firms often cited frustration with their employers, often related to having an idea about an innovation or new submarket rejected. If the innovation is based on protected intellectual property, a corporate spin-off may be the only legal path to commercialization.

Teece (1988) suggests that by preserving the relationship with the parent, the spin-off may combine the advantages of maintaining the entrepreneurship of a small firm and utilizing the existing assets of a large corporation. In other words, the spin-off founder may seek to improve the probability of the new venture's success, or seek competitive advantage that could improve the magnitude of that success. According to Richards (2001), the parent may provide resources and facilities (including physical space, e-commerce support, Internet access, office equipment, legal and accounting services, management and staff recruiting, and industry-specific resources), assistance in developing non-core business components, qualified mentoring and

coaching, access to a peer-level support network of other spin-off entrepreneurs, and help raise capital appropriate to the business. Some of these services are the same ones provided by external *networked incubators* (Hansen, Chesbrough, Nohria & Sull, 2000), *angel investors* (Fenn, Liang & Prowse, 1997), and some high-service venture capital firm specializing in early-stage seed investment. Nonetheless, with corporate ventured spin-offs, these services may be explicit.

Sahlman (1992) suggests that a spin-off that originates as an internal project may have lower consequences of failure than an independent start-up. Founders and staff may be able to return to the parent if the venture is not successful.

In summary, the management literature suggests that an entrepreneur may be motivated to form a spin-off by the opportunity to commercialize an innovation that would not otherwise be available, to gain access to assets and services that may improve the probability and magnitude of venture success, and to reduce the consequences of failure.

2.5.2 Investors

The role of venture capital in the innovation process is surveyed by Callahan & Muegge (2003).

New ventures suffer from four fundamental problems that make them ineligible for conventional debt financing – high uncertainty, information asymmetry, intangible soft assets, and sensitivity to volatile market conditions (Gompers & Lerner, 2001b). Venture capital (VC) is a specialized form of risk financing that fills this void by providing high levels of funding to a minority of entrepreneurs in attractive industries. In addition to funding, venture capital investors (venture capitalists, or VCs) can provide specialized knowledge of a particular industry, experience successfully growing a business from start-up to publicly traded company, and access to a network of contacts that may include seasoned managers, partners, and customers. The venture capitalist brings terms, controls, expertise, and financial strength that help form a well-managed and well-financed company that is more likely to succeed. In exchange, the venture capitalist demands a preferred equity share of the new venture, along with favorable upside and downside investment protections. The founding entrepreneurs relinquish equity and agree to contractual restrictions intended to protect the venture investment. In doing

so, the founders give up exclusive ownership of the whole pie for the possibility of owning a small slice of a much larger pie when the firm is taken public or acquired.

VCs are able to effectively exit their investments only at a liquidity event – an initial public offering of stock (IPO) on a public stock exchange, acquisition of the firm by another firm, or bankruptcy. Other liquidity events (such as buy-out by the founding team) are possible but rare. The IPO is the most lucrative result for all investors (Cummings & MacIntosh, 2002), so in principle, the interests of the founders and venture capital investors align in this regard. However, entrepreneurship is inherently risky, and most VC-backed firms fail (Nesheim, 2000; Bhide, 2000). More privately held companies are acquired than go public (Nesheim, 2000, p. 267). Investors expect to make their returns on a small number of very large successes (Zider, 1998).

VCs are very active investors who influence the commercialization strategies of their investments (Hsu, 2000; Chesbrough & Rosenbloom, 2002). Commonly, they participate as active members of the board of directors, recruit management and key technical personnel, develop business strategies, monitor the company's performance, and facilitate subsequent financing rounds (Kaplan & Stromberg, 2000a, 2000b, 2001). VC-backed firms are more likely to be successful than non-VC-backed firms. Venture-backed firms bring product to market faster (Hellmann & Puri, 2000), 'professionalize' earlier by adopting stock option plans and hiring external business executives (Hellmann & Puri, 2002), time IPOs more effectively to the market (Lerner, 1994), and have higher valuations at least five years after IPO (Brav & Gompers, 1997). Venture-backed IPOs pay lower fees and are less under-priced (Megginson & Weiss, 1991).

The supply of venture capital money and the willingness of VCs to invest are strongly dependent on the state of the equity markets and other market forces (Sahlman, 1992). VC investment favors certain industries (Zider, 1998) and geographical regions (Gompers and Lerner, 2001a). The geographical clustering appears to be explained by two closely related factors. First, VCs tend to invest close to home. Lerner (1995) reports that over half the venture-backed firms in a biotechnology sample had a venture director with an office within 60 miles of their headquarters. Second, regions with large venture capital activity develop *agglomeration economies* (Gompers & Lerner, 1999a) that further favor venture capital through

a virtuous circle of improved process efficiency. Intermediaries familiar with the workings of the venture process, particularly lawyers, accountants, and real estate brokers, reduce the transaction costs associated with forming and financing new firms. Agglomeration economies are closely related to the notion of *regional technology clusters*, defined by Porter & Stern (2001) as "a geographically proximate group of inter-connected companies and associated institutions in a particular field, linked by commonalities and complementarities." Two of the largest and most recognized technology clusters are located in the United States – Silicon Valley in California (Saxenian, 1994), and Route 128 that circles Boston Massachusetts (Dorfman, 1983). The states of California and Massachusetts accounted for 42% and 11% respectively of U.S. venture capital disbursements in the third quarter of 2002 (PricewaterhouseCoopers, 2003). The Ottawa region is Canada's largest and most mature technology cluster (Ghent-Mallet, 2002).

In summary, the management literature suggests that VC investors are motivated to invest in spin-offs by the same incentives that motivate them to invest in start-ups – the possibility of high financial returns should the venture achieve a successful liquidity event such as IPO or acquisition.

2.5.3 The Parent Firm

From the perspective of the parent corporation, spin-off formation and "intrapreneurship" programs are one possible mechanism to invest in new businesses. However, section 2.3 reviewed some of the unique challenges that corporate ventures face. Why then, would a parent corporation seek to spin-off a new venture in the face of such obstacles? The literature identifies the following possible motivations:

- Develop a disruptive technology that would likely fail if developed internally by the parent. (Christensen, 1997)
- Retain an equity stake in a promising venture that would not have been funded internally. (Anslinger, Carey, Fink & Gagnon, 1997)
- Resolve mismatched business models (Anslinger, Bonini & Patsalos-Fox, 2000)
- Create shareholder value through four mechanisms: increase coverage by analysts, attract new investors, improve operating performance through such means as new incentives to management, and improve strategic flexibility. (Anslinger, Klepper & Subramaniam, 1999)
- Generate capital for acquisitions or internal growth. (Annema, 2002)
- Receive favorable tax treatment (Annema, Fallon & Goedhart, 2002)

- Retain and attract top talent (Anslinger, Carey, Fink & Gagnon, 1997; Hellmann, 2003)
- Motivate future innovation and entrepreneurship within the parent (Day & Wendler, 1998; Hamel, 2000)
- Distance the parent company from a viable, but more slowly growing business (Anslinger, Carey, Fink & Gagnon, 1997)
- Avoid a bad reputation during periods of downsizing (Lindholm Dahlstrand, 1997).
- Gain access to external risk capital (Lindholm Dahlstrand, 2001).

Christensen's (1997) work (reviewed in section 2.1) suggests that a corporate spin-off may be one viable tactic for an established corporation to commercialize a disruptive technology that changes the basis of competition in its industry. He notes:

"With few exceptions, the only instances in which mainstream firms have successfully established a timely position in a disruptive technology were those in which the firms' managers set up an autonomous organization charged with building a new and independent business around the disruptive technology."
(Christensen, 1997, p. xix)

Spinning-off the commercialization of a potentially disruptive technology could create an autonomous organization that may be more likely to succeed, limit the parent's liability if the venture should fail, and position the parent corporation to profit should the venture succeed.

Chesbrough (2002) proposes a corporate venture capital investment framework that may be equally applicable to CV programs and spin-off formation. The framework is defined according to two characteristics – *objective* (strategic or financial) and *degree of linkage to operational capabilities* (tight or loose). The resulting four investment types are *driving* (advances the strategy of current business), *emergent* (allows exploration potential new businesses), *enabling* (complements the strategy of current business), or *passive* (providing financial return only). The parent should approach each investment type differently. For example, enabling and driving investments promote the growth of the core business and should not be measured strictly by the financial returns of the venture.

Mason & Rohner (2001) argue that corporate venturing can be a key component of a corporate strategy, and propose the creation of a *venture business office* (VBO) as a source of competitive advantage for corporations. In this model, corporate ventured technology spin-offs would be part of a portfolio of both internal and external investments that would permit companies to seize technology opportunities, integrate different innovation approaches, and

approach innovation as a highly structured and on-going process.

In summary, the management literature suggests that a parent corporation may be motivated to form a spin-off in pursuit of either strategic or financial gains. Strategic investments seek to improve the performance of an existing business. Financial investments aim to create revenue and profit from the new venture itself. Some innovations may be more successfully commercialized as spin-offs rather than internal business units. A corporation may seek to institutionalize corporate venturing as a sustained source of competitive advantage.

2.6 The Quest for Legitimacy

Block & MacMillan (1993, p. 285) observe that venture managers often have to overcome problems of legitimacy, both inside and outside the organization. To overcome low legitimacy, a venture must secure endorsements that will convince the necessary supporters of the venture's viability and credibility.

Aldrich & Fiol (1994) distinguish between *cognitive legitimacy* and *sociopolitical legitimacy*, and suggest that the lack of legitimacy may be a liability to entrepreneurs with newly formed businesses. *Cognitive legitimacy* is how "taken for granted" a new form is, measured by the level of common knowledge. *Sociopolitical legitimacy* is the extent to which a new form conforms to recognized principles or accepted rules or standards; it is the extent to which key stakeholders accept a venture as appropriate or right given existing norms. Generating and sustaining trusting relationships are at the heart of overcoming low legitimacy.

Schoonhoven & Eisenhardt (1996) observe that founders with previous experience in the industry and externally visible positions within the parent firm were better able to increase their firms' rates of strategic alliance formation. Successful past career experiences and access to influential partners may have substantial economic benefits, measured by profitability, alliance formation, and rates of founding and growth. This is closely related to the notion of legitimacy.

Burton, Sorensen, & Beckman (2001) introduce the notion of *entrepreneurial prominence* – that resources accrue to entrepreneurs based on the structural position of their prior employer. Information advantages allow individuals from entrepreneurially prominent firms to identify new opportunities. Entrepreneurial prominence provides reputation benefits that reduce the perceived

uncertainty of a new venture in the eyes of external constituents.

2.7 Business Model Discovery

Chesbrough & Rosenbloom (2002) expand on earlier work by Andrews (1971) to suggest that the *business model* mediates between technology development and economic creation. They propose the following definition for business model:

- Articulation of the *value proposition*, i.e. the value created for users.
- Identification of a *market segment*, i.e. the users to whom the technology is useful.
- Definition of the vertical *value chain* within which the firm creates and distributes the offering. The value chain disaggregates a firm into its strategically relevant activities in order to understand the behavior of costs and the existing and potential sources of differentiation (Porter, 1985).
- Estimation of the *cost and profit*, i.e. the cost structure of producing the offering and the profit potential.
- Description of the *value network* linking suppliers and customers, including potential complementors and competitors (Christensen & Rosenbloom, 1995).
- Formulation of the *competitive strategy* by which the innovating firm will gain and hold advantage over rivals.

The set of all feasible business models is not foreseeable in advance. Rather, an appropriate business model is "discovered" through heuristic logic. A technology that makes little or no business sense in a traditional business model may yield great value in a different business model.

Chesbrough & Rosenbloom (2002) combine the concepts of business model and sensemaking (Weick, 1995) constrained by the cognitive biases of experienced managers (Prahalad & Bettis, 1996; Abernathy, Clark & Kantrow, 1983; Tushman & Anderson, 1986; Henderson & Clark, 1990; Christensen, 1997) with the analysis of six case studies (Chesbrough & Smith, 2000) to propose some hypotheses regarding entrepreneurship. The most relevant conjectures for this study are the following:

- An initial business model is more of a tentative hypothesis, an initial foray into a market, than it is a fully elaborated and defined plan of action.
- The ultimate business model of the most successful firms emerged from an interactive process of adaptation that involved the entrepreneurs' robust vision of latent opportunity tempered by adaptation in response to substantive interactions with potential customers and sources of funding.
- The process of reshaping an initial business model creates learning opportunities that themselves may contribute importantly to success.
- Conducting the process within a successful established firm is likely to preclude identification of models that differ substantially from the firm's current business model.
- The process of business model adaptation is either more highly motivated or more easily implemented in independent firms.

3 Theoretical Frameworks

This section briefly summarizes four theoretical perspectives on spin-off firms. The intention here is not to deduce hypotheses from theory, but rather:

- 1) demonstrate that theory supports the notion that different categories of spin-offs may have different decision and resource environments;
- 2) provide theoretical support that decision and resource environments may be important determinants of future performance;
- 3) introduce perspectives that will be accessed later during the discussion of grounded results.

The last part of this section builds on these perspectives to develop the elements of the two new theoretical constructs introduced in this study – the *decision environment* and the *resource environment*.

The terminology of these constructs was inspired by Goel & Pirolli's (1992) cognitive science work on the structure of design problem spaces. In their analysis framework, they employ the notion of a *task environment*, derived from Newell & Simon's (1972) information-processing theory of human problem solving. Entrepreneurism shares many qualities with design; it is an ill-structured problem, with tasks involving underspecified goals and operators, and requiring logical and creative elements.

The *decision environment* is defined as the totality of circumstances and conditions that surround the decision-making entrepreneur. It includes the scope of possible decisions, the set of all possible courses of action (for example, the possible solutions to a specific problem), and various factors that could influence the decision-making entrepreneur. It does not describe how a particular decision-making entrepreneur arrives at a particular decision; rather it characterizes the environment in which an entrepreneur makes decisions, irrespective of their particular evaluation criteria and decision-making process.

The *resource environment* is defined as the set of all possible resources that an entrepreneur has available, including money, time, people, reputation, support (technical,

managerial, psychological), and established relationships (customers, suppliers, investors, key talent). The decision-making entrepreneur employs these resources to assist with decision-making, and deploys these resources to execute their decisions.

3.1 Resource Based Theory

Resource based theory (Penrose, 1959; Wernerfelt, 1984, 1989) proposes that a firm can gain sustainable competitive advantage (Barney, 1991) through the accumulation of strategic resources. Strategic resources can be classified in the following three categories: physical capital resources, human capital resources, and organizational capital resources. Firms may be heterogeneous with respect to the strategic resources they control. Strategic resources may not be perfectly mobile, that is, they are not easily bought and sold. Thus, a firm with a stronger mix of resources may be more effective than a competitor at responding to opportunities, neutralizing threats, and avoiding its own weaknesses.

Resource based theory implies that the resource environment of a new venture could potentially be an important determinant of that firm's performance.

3.2 Resource Dependence Theory

Resource dependence theory maintains that the survival and performance of a firm depend on that firm's ability to acquire and maintain resources through reciprocal resource exchange relationships (Pfeffer & Salancik, 1978; Seabright, Leventhal & Fichman, 1992). Because firms rarely house all necessary resources and expertise in-house, their behavior becomes externally focused on attending to the demands of the sources of those resources.

Christensen (1997) applies resource dependence theory to account for the innovator's dilemma – the failure of many previously successful established firms to maintain market leadership when faced with disruptive technologies that change the basis of competition in an industry. Successful managers focus their resources on attending to the demands of their current markets and customers – the sources of revenue that make them successful. They do not "waste" resources on the needs of potential markets and customers that do not provide strong revenue potential. Thus established firms tend to be effective at exploiting technology opportunities that reinforce their current business, but ineffective at exploiting opportunities that disrupt their

current business.

Like established corporations, new ventures depend on markets and customers to supply revenue. Often however, the success of new ventures in the technology sector also depends on external investors who supply the growth capital to grow the business to profitability. The success of a corporate ventured technology spin-off may also depend on resources controlled by the corporate parent, such as knowledge, access to the parent's customer and supplier channels, approval for major governance changes, permission to make lower-level decisions without seeking approval, and assistance with raising venture capital. To acquire and maintain these resources, a corporate ventured technology spin-off would focus some attention on satisfying the interests of the parent corporation. If those interests were different from the interests of other investors (which they may be, as shown in section 2.5.3), the decision environment of a corporate ventured technology spin-off would be expected to be different from that of an independent start-up.

Likewise, the financial or strategic benefits that could accrue to a corporate parent from its investment in a corporate ventured technology spin-off can be treated as a resource. If so, the corporate parent has an incentive to expend some effort on attending to the needs of its investment. The parent's contribution to the resource exchange relationship may include resources that would be unavailable to an independent start-up.

Resource dependence theory implies that decision and resource environments of an entrepreneur within a spin-off may be different from those of an entrepreneur within a VC-backed start-up, and that the decision environment of a new venture may potentially be an important determinant of the firm's performance.

3.3 Game Theory

Game theory (Dixit & Skeath, 1999) is a branch of mathematical analysis developed to study decision making in conflict situations. Such a situation occurs where two or more decision makers act on the same system.

Investors and entrepreneurs all want a venture to be successful. However, in any situation as complex as building a new company, there can be many versions of success

(Callahan & Muegge, 2003; Callahan & Sharp, 1985). Section 2.5 showed that the possible motivations of the various participants are not necessarily all the same.

Cable & Shane (1997) employ game theory to construct a *Prisoner's Dilemma* framework of the post-investment entrepreneur – venture capital relationship. The essence of the dilemma is that each individual actor has an incentive to act according to competitive, narrow self-interest even though all actors are collectively better off if they cooperate. An actor may choose to *cooperate* (seek mutual gains at the expense of short-term self-interest) or *defect* (seek individual gains at the expense of long-term mutual benefit). The payoffs for each actor are dictated by the strategy adopted by the other actor. The payoff structure is $T > R > P > S$, where T is the temptation of extra payoff from defection where the other actor cooperates, R is the reward for mutual cooperation, P is the penalty of mutual defection, and S is the sucker's payout – the penalty for cooperating while the other actor defects. Mutual cooperation is critical to the success of the entrepreneur-venture capitalist relationship. However, each may be tempted to defect by acting according to immediate self-interest at the expense of mutual cooperation. The motivation for defection is linked inextricably to the uncertainty of new ventures, opportunity costs, and asymmetric information. An entrepreneur may defect by withholding or altering critical information, behaving in a way that is detrimental to the venture, or misusing capital. A venture capitalist may defect by harvesting profits early, forcing the venture to focus on short-term performance at the expense of long-term performance, or under-invest in terms of either capital or time. The study concludes by hypothesizing a set of determinants to improve the likelihood of cooperation, including the payoff to cooperation, personal similarity, information flow, time pressure, and transaction procedures.

The motivations of a corporate investor and a venture capital investor may differ. By definition, venture capital investors are motivated to seek profits for themselves and their investors by growing and liquidating the investments in their portfolio. A parent corporation is also motivated to seek profits for its shareholders, but its motivation for investing in a particular spin-off may be different from that of a VC. First, a corporate parent is likely to be very diversified compared to a VC investor. Second, a spin-off may represent a strategic investment intended to improve the profitability of a core business unit within the parent. If so, the parent

may be less motivated to seek financial returns from the venture. In fact, Siegel, Siegel & MacMillan (1988) show that parental intervention to align a corporate venture with strategic interests is likely to reduce financial performance. Third, a parent has an additional set of motivations related to their core business, including protecting their brand value and winning against their competition. Thus, the parent introduces a new set of objectives into the game, and may make cooperation and defection decisions differently.

Game theory implies that the decision environment of an entrepreneur within a spin-off may be different from that of an entrepreneur within a VC-backed start-up.

3.4 Organizational Ecology

The organizational ecology perspective investigates the evolutionary trends of organizations.

Stinchcombe (1965) was one of the first organizational theorists to emphasize the founding period, arguing that events surrounding the creation of new organizations have a long-lasting effect on its subsequent development. Boeker (1988, 1989) tested Stinchcombe's *organizational imprinting* theory on a sample of Silicon Valley semiconductor firms, and found that organizations are set on a course at founding from which change may be difficult or costly. Early patterns set boundaries on the range of strategic actions by contributing to an internal consensus around a given strategic approach, and only a very strong external or internal event is likely to motivate significant change. Conditions subsequent to founding also influence the degree to which an initial strategy is perpetuated. Baron, Burton & Hannan (1999) discovered *path-dependent behavior* within new ventures, where the initial visions and management styles of the founders remained relatively unchanged even if the founders were no longer with the firm.

The organizational ecology perspective implies that early decisions at a new venture have a lasting impact on future decisions that may outlast the direct influence of the founders. Thus the decision and resource environments at the formation of a new venture may be important determinants of not only the early performance of the venture, but its future performance as well.

3.5 Construct Development

Four theoretical perspectives (resource theory, resource dependence theory, game theory, and organizational ecology) have been used to construct a theoretical foundation for the decision environment and resource environment. With this foundation in place, the theoretical management literature was set aside. There were three reasons for this. First, these theoretical perspectives were developed primarily for analysis of large corporations or organizations. The specific direction in which these perspectives have developed may not necessarily address the most relevant determinants of new venture performance, the concerns of entrepreneurs and their investors, or the characteristics of small organizations where individual decision-makers may wield great influence. Second, these perspectives represent mature deductive research traditions that could introduce researcher biases towards extant theory. Such biases are at odds with the study objectives to inductively discover anomalies and extend extant theory (see section 1.4). Third, these constructs are not intended to impose or assume a particular decision-making model. Different decision-makers could employ different evaluation criteria and different methods to arrive at decision. Such methods could be fully rational, or exhibit bounded rationality.

The elements comprising the decision and resource environments were developed from stakeholder analysis, then further refined inductively from case study data and interviews with practitioners. They were not derived from published lists of firm attributes based on resource theory (Hitt & Ireland, 1986; Thompson & Strickland, 1983). Rather, they represent the main concerns of practitioners in this study.

Initial lines of inquiry were established using stakeholder analysis (Smi, 2000). The rationale for selecting that approach was as follows. Relationships are thought by many to be a competitive resource for entrepreneurs and new technology ventures (Schoonhoven & Eisenhardt, 1996). Building new and stronger relationships may require a significant investment in time and effort. Therefore, identifying the stakeholders of a new venture, their relationships to the venture, and the possible incentives that would motivate their interests in that venture served as a starting point. The new venture had relationships to the following external stakeholders: customers, suppliers, partners, competitors, risk capital investors (friends and family, angel investors, seed investors, venture capital investors, private institutional investors), liquidity and

post-liquidity investors (investment banks, public investors, mutual fund managers, institutional investors). The new venture had relationships to the following internal stakeholders: directors, founders, the executive management team, and the workforce. For each relationship, the possible motivations of each stakeholder participant were considered, along with the possible parameters that could describe that relationship. This tentative framework suggested possible lines of inquiry to be explored at participant interviews.

These lines of inquiry were tested at four preliminary interviews with practitioners familiar with start-up and spin-off firms (as described in section 4.1.1). The respondents included a venture capital partner, a well-connected entrepreneur and angel investor, a financial consultant who advises new ventures, and an academic who has advised corporations on innovation.

The definition, theoretical foundations, and the identity of the constituent elements comprising these constructs were continuously refined throughout the study. Through the grounded theory logic of constant comparison (see section 4.1.5), the emergent elements of the decision and resource environments represent the main concerns of the practitioners of this study.

The emergent constructs are fully described in sections 5.5 and 5.6.

4 Research Design

The literature survey (section 2) has shown that corporate ventured technology spin-offs fall within the overlap of two research streams – corporate spin-offs and corporate venturing. There is no dominant paradigm, no generally accepted typology, and no agreement among researchers or practitioners regarding the usage of terminology.

From the perspective of the Christensen et al. (2002) theory-building model, theory regarding corporate ventured technology spin-offs would appear to be in a *pre-paradigmatic theory-building cycle* (Kuhn, 1962). In such a cycle, the most productive emphasis of researchers is not the development of methods of measurement for categorization and prediction, but rather conceptual definition of categories and the search for anomalies. The methods of this study were selected with that objective in mind.

The research design of this study is *multiple case study* (Yin, 1989) using *grounded theory* logic (Glaser & Strauss, 1967) and *qualitative cross-case analysis* (Miles & Huberman, 1994). This is inductive-mode research that builds theory directly from observed data. It generates rather than tests hypotheses.

4.1 Methods

The theory-building methods here are similar to those recommended by Eisenhardt (1989), and employed by Brown & Eisenhardt (1997) and Bessant (1998) for exploratory studies of other management phenomena.

The unit of analysis is the entrepreneurial new venture. Eight cases are developed and examined as independent experiments that confirm or disconfirm emerging conceptual insights (Yin, 1989). The primary data sources are fifteen semi-structured interviews with individual respondents. The set of respondents includes both the *founder* and *investor* perspectives on seven of the eight cases. Interviews included *open-ended questions* to initiate stories, and *probing questions* to establish details, conducted according to accepted interviewing best practices (Foddy, 1993). Secondary data sources included corporate websites, press releases, quarterly and annual financial reports, independent analyst reports, and media coverage.

The underlying logic of this research is *grounded theory building* from field-based case

data. According to Glaser & Strauss (1967), grounded theory is appropriate for investigating rarely explored phenomena for which extant theory is not applicable. In such situations, an exploratory grounded theory-building approach is more likely to generate novel and accurate insights into the phenomenon under study than is reliance on either past research or office-bound thought experiments. Christensen et al. (2002) relates grounded theory to the categorization stage of theory-building, where researchers classify phenomena into categories of similar things that highlight the most meaningful differences. From both perspectives, grounded theory is an appropriate logic to meet the objectives of this study.

The standard grounded theory procedures developed for participant observation in the social sciences (Glaser & Strauss, 1967) are adapted here to address differences in the form of theory and the nature of the data of management research (Eisenhardt, 1989; Partington, 2000). In summary, the grounded theory procedures here differ from those recommended by Glaser (1998) as follows:

- Theoretical sampling was resource-limited by time and budget, with a target of eight cases established at the proposal stage.
- Most interviews, particularly early in the data collection process, were recorded and transcribed.
- Theory is presented as causal diagrams and hypotheses of cause and effect. This format was deemed to be more useful to management researchers than the monograph formats favored in sociology research.
- Hypotheses proposed by interview respondents were explicitly documented for later comparison against the emergent theory (see section 5.2).

Figure 4 is a simplified diagram of the research methods employed in this study. When faced with conflicting guidance in the literature regarding specific methods, emergent methods (Glaser, 1978, 1992, 1998) were favored over proceduralized methods (Strauss & Corbin, 1990).

The structure of the following sections closely follows the research stages recommended by Eisenhardt (1989) for building management theory from case-based research. As suggested by Figure 4, the execution of these stages was highly parallel and iterative.

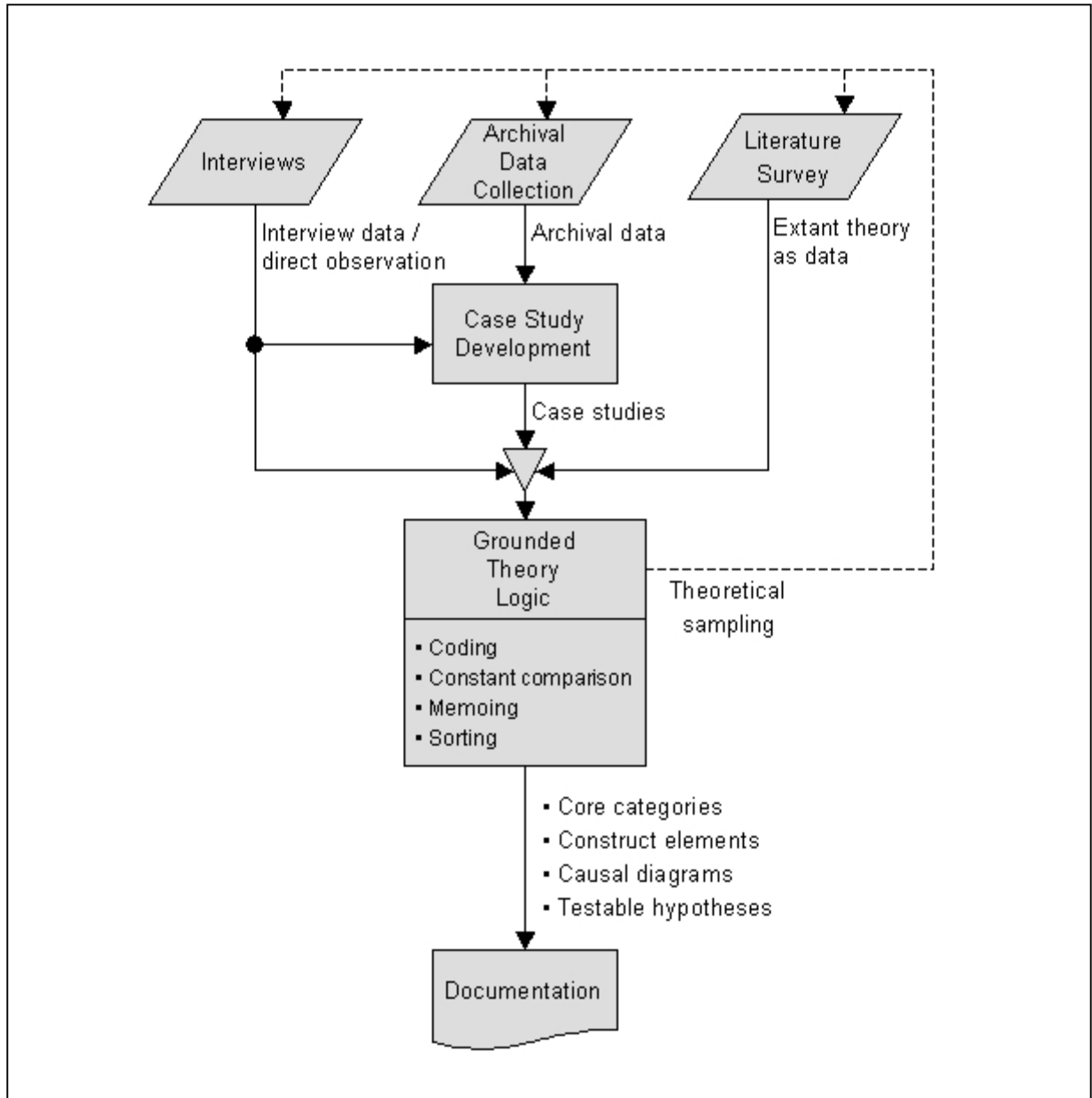

Figure 4: Research methods

4.1.1 Preliminary Work

After defining the research question, a preliminary literature survey was conducted. Care was taken to heed Dick's (2000) advice to access the literature *only as it becomes relevant*, thus keeping theoretical sensitivity sharp (Glaser, 1978) and eschewing researcher bias towards preconceived concepts that may not be relevant (Glaser, 1992).

Preliminary references that shaped the evolution of this study included readings on theory-building and research methods (Eisenhardt, 1989; Glaser & Strauss, 1967; Glaser, 1998; Yin, 1989; Miles & Huberman, 1994; Dick, 2000), innovation in mature corporations (Christensen, 1997), spin-offs (Klepper, 2001), business model discovery (Chesbrough & Rosenbloom, 2002), and corporate venturing (Chesbrough, 2000).

Stakeholder analysis (Smi, 2000) was employed to identify possible lines of inquiry and develop preliminary a priori constructs of the decision and resource environments. This process was fully described in section 3.5. These lines of inquiry were tested at four preliminary interviews with practitioners familiar with start-up and spin-off firms. The respondents included a venture capital partner, a well-connected entrepreneur and angel investor, a financial consultant who advises new ventures, and an academic who has advised corporations on innovation. The definition, theoretical foundations, and the identity of the constituent elements comprising these constructs were continuously refined throughout the study.

4.1.2 Selecting Cases

Cases were selected using *theoretical sampling* (Glaser, 1978), with the goal to sample towards saturation and theoretical completeness. At the proposal stage, a target of eight cases was established based on pragmatic time and resource constraints. Glaser (1998) and Dick (2000) agree that saturation constraints are an acceptable compromise for graduate thesis research employing grounded theory. This target was within Eisenhardt's (1989) recommended guidelines of four to ten cases for case-based management research.

All cases were new ventures founded by former employees of Nortel Networks. Restricting the sample space to one parent corporation controlled for *entrepreneurial prominence* of the parent (Burton, Sorensen & Beckman, 2001), and at the corporate level, the *established routines* (Nelson & Winter, 1982), *knowledge biases* (Wright, 1997), and *dominant logic*

(Prahalad & Bettis, 1986) of the founding entrepreneurs.

All cases were located in the region of Ottawa Canada, in the Ottawa-Gatineau technology cluster, also known as Silicon Valley North (Ghent-Mallet, 2002). A new venture was considered "located in" Ottawa if either its corporate headquarters or largest office (measured by number of staff) had an address within the Ottawa-Gatineau region. Restricting the sample space to one geographical region controlled for many external environmental factors, including the legal and regulatory climate (Hellmann, 2003), cultural norms, and the local resource base (Porter, 1998, 2000; Porter & Stern, 2001).

There were several motivating factors for selecting Nortel and Ottawa as the boundaries of the sample space. First, the data set of recent Ottawa new ventures founded by former employees of Nortel Networks has not been previously reported in the published management literature. Second, Ottawa-Gatineau is Canada's largest, most mature, and most widely recognized technology cluster (Ghent-Mallet, 2002), and Nortel is the largest private sector employer in the Ottawa region. In the first quarter of 2001, Ottawa firms attracted nearly half of the venture capital invested in Canadian start-ups – a C\$325M share of C\$785M total investment (Pilieci, 2001). Third, Nortel and Ottawa offer a large sample space of new ventures. Doyle (2002) traces the origins of Ottawa technology companies formed after 1965, with the main criterion for source identification being the premise that the company would not have existed if either the people or technology had not been involved at that point in time. Of the approximately nine hundred companies traced by Doyle, Nortel was the main source of more than two hundred companies, making it the largest private-sector source of new ventures in the Ottawa region. In the period of corporate restructuring between the dot-com collapse of April 2000 and October 2002, over two hundred new start-ups formed in Ottawa (Thompson, 2002). Fourth, Carleton University is located in Ottawa so the region is a convenient sample space for the researcher.

The sample space was further restricted to new ventures that were founded no earlier than January 1992 and no later than December 2001. This ten-year interval included one complete corporate venturing market cycle (see section 2.3), four different CEOs at the parent corporation, the emergence of the Internet, the dot-com boom, the dot-com collapse, and the technology meltdown of 2001.

A list of twenty-five candidate firms was compiled from local media articles, various web-based services that track Ottawa-area start-ups, and the recommendations of the four preliminary interview respondents. Information was collected on each candidate, including the circumstances of its founding, the address of the company website, the names of the founders, the product or service offering, the company's financing history, and the names of its investors. The candidates did not necessarily need to achieve successful liquidity events, nor did they need to be currently active as independent ventures. The only additional restriction, other than the boundaries on the sample space already noted, was the requirement that both a founder and investor were expected to be accessible as interview respondents.

Five candidate firms were initially selected for inclusion as cases. These firms represented a broad diversity of founding circumstances and had founders that were deemed likely to participate. Founders of each candidate firm were contacted with an invitation to join the research project. Four founders agreed to participate in the study; one founder did not respond to the invitation, and was thus excluded.

After the data on the first four cases had been partially collected and analyzed (see sections 4.1.3 through 4.1.5), two more candidates were selected based on their potential to extend the emergent theory. Founders from both candidate firms agreed to participate. After the data on the fifth and sixth cases had been collected and analyzed, the final two candidates were selected. Founders from both candidate firms also agreed to participate, and these became the seventh and eighth cases of this study. Over all, of the nine candidate firms invited to participate, eight firms were developed into research cases.

4.1.3 Instruments and Protocols

The development of potential lines of inquiry and a priori constructs was discussed in section 4.1.1.

The data collection process was structured to encourage triangulation (Jick, 1979) of multiple data sources. The data on each case included:

- interviews with at least one founder and one investor
- archival sources including media coverage, financial documents, existing case

studies, company website content, press releases, and marketing collateral

- relevant remarks from other interview respondents

The investor respondent for an independent venture was generally a venture capital or angel investor. The investor respondent for a corporate ventured spin-off was either a venture capital investor or an executive from the parent corporation who was familiar with the spin-off. An exception was made for one case, a small bootstrapped new venture with no external investors. By the principles of theoretical sampling, interview data from one founder respondent along with archival data was deemed sufficient to adequately characterize this venture.

The format of each interview was semi-structured, with open-ended questions to initiate stories, and probing questions to establish details. The interview protocol adopted the best practices recommended by Foddy (1993). In particular, Foddy recommends that the interviewer frame the objective of the study at the beginning of the interview, and frame the context of each question by specifying the required perspective. The questions were designed to be short, grammatically simple, and non-threatening to the respondent. Probes encouraged concrete examples to back up abstractions.

An interview guide was prepared prior to each interview. The guide summarized the open-ended questions intended for that particular respondent. Questions covered the general lines of inquiry established earlier, such as founding history, business model (using the operationalized definition of Chesbrough & Rosenbloom, 2002), financing history, interaction with investors and the parent firm, the board of directors, corporate culture, customers, and suppliers. Other questions would solicit unique information from a particular respondent to extend the emergent theory.

4.1.4 Entering the Field

A total of fifteen interviews were conducted. Twelve interviews were conducted face-to-face, and three were conducted by telephone. Interview duration ranged from thirty minutes to two hours, with a typical duration of approximately ninety minutes. Some interview respondents, particularly corporate executives and investors, were able to provide insights on more than one case.

Prior to each interview, the interviewer reviewed available archival sources, noting any gaps, discrepancies, and interesting insights for follow-up during the interview. Via email, the respondent was provided with a description of the research question, an overview of the interview format, and a list of the general topics to be discussed.

At the start of each interview, the respondent was reminded again of the research question and the general topics to be discussed.

At each interview, the interviewer recorded key-point notes during the responses. Eleven of the interviews were tape-recorded and subsequently transcribed by a transcription service.

After each interview, the interviewer added any subjective impressions as an addendum to the key-point notes.

4.1.5 Analyzing Data

Hypotheses proposed by interview respondents were explicitly documented for later comparison against the emergent theory (see section 5.2). These speculations were mined for possible lines of inquiry in data collection and analysis, but were not used as data in developing the emergent theory. Possible "forcing" of the data towards practitioner biases was controlled through the grounded theory methods of constant comparison, and explicitly documenting these possible biases.

Eleven descriptive case studies were developed, including cases for the eight new ventures under study, the parent corporation, the Nortel Business Ventures Program, and the Ottawa-Gatineau technology cluster. The descriptive case studies ranged in length from five to sixteen pages, with a combined length of one hundred and four pages. Each case shared a common format that included a boilerplate summary, a historical timeline recording the dates of standard milestones in the growth of a new venture (Kazanjian, 1988; Kazanjian & Drazin, 1989), a technical overview the firm's technology, a description of the business model (including the market segment, value proposition, element of the value chain, identified cost and profit, position in the value network, and competitive strategy), a history of business model churn, a descriptive history of the firm (including origins, formation, incubation, spin-off, growth as a private firm, liquidity, and post-liquidity), the founders, and the board of directors.

Interview transcripts and key-point notes were coded (Glaser, 1978; Miles & Huberman, 1994, chapter 4), and those codes were entered manually into a case study database. The initial list of open codes (Glaser, 1998) was based on the lines of inquiry established through stakeholder analysis and early exploratory interviews. The coding list was expanded and refined throughout the study by inductively adding, eliminating, clustering, refining, and sorting codes in response to emergent researcher insights and the main concerns of the interview subjects. The final coding list had a combined total of 62 substantive and theoretical codes.

In parallel, the descriptive case studies were edited and restructured to facilitate comparison across the emergent categories. Case study data was selectively added to the coding database as new codes were discovered.

Short quotes from interview respondents were included in the descriptive case studies and the coding database for possible inclusion in the final report.

The case study database was a Microsoft Excel spreadsheet that could be filtered and sorted to create data displays of the coded data. At the completion of the data analysis phase, the final spreadsheet had approximately eight hundred entries and filled thirty-two printed pages.

Expanded tabular data displays (Miles & Huberman, 1994) were created to further explore some emergent categories. Possible relationships and emergent hypotheses were recorded as causal maps and collected together in a memos folder along with other insights.

No significant discrepancies were observed between triangulated data sources (see section 4.1.3). If there had been discrepancies, they would have been managed through the grounded theory processes of constant comparison and theoretical sampling. Additional data would have been gathered (possibly including archival records and additional interview respondents) based on the data's potential to resolve the discrepancy. The existence of a discrepancy would have become data to be analyzed and understood.

4.1.6 Shaping Hypotheses

The memos folder was reviewed at the completion of each new case and periodically at other times throughout the study. Each pass resulted in more memos and refinement of the codes and categories.

Once the core categories and most elements of the decision environment and resource environment had emerged and stabilized, detailed comparison charts were developed for each construct. The coding database was again revised and the codes were further refined.

Possible causal relationships between categories were noted on memos along with alternative explanations.

Finally, once the causal relationships between categories had stabilized and the resulting grounded theory could account for most of the behavior in the observed data set, causal maps were constructed of each category illustrating the hypothesized relationships to other categories. Each relationship was articulated as a testable hypothesis. The emergent hypotheses are compiled in section 5.7.

4.1.7 Enfolding Literature

As noted in section 4.1.1, the management literature was accessed throughout the research design, data collection, and analysis phases as it became relevant in response to emergent relationships discovered in the data. Extant literature became data, treated with equal weight to case study and interview data, and subjected to the same grounded theory logic of constant comparison.

Relevant research streams included cognitive bias, legitimacy, corporate governance, intellectual property, power in organizations, and executive champions. Empirical studies of spin-offs, entrepreneurship, and venture capital investment were also accessed in the late stages of the study. Recent dissertations such as Lindholm (1994), Parhankangas (1999), and Tübke (2001) were accessed only in the late stages of data analysis to avoid biasing the emergence of core categories toward their proposed typologies.

The extant literature suggested some hypotheses that improved the theoretical completeness of the grounded theory. Those hypotheses that withstood the rigors of constant comparison with case study data were included in the emergent theory. In each instance where a hypothesis was inspired by the literature, this is noted in the appropriate section where the hypothesis is developed.

4.1.8 Reaching Closure

The resulting grounded theory accounts for most of the observed behavior in the eight cases. It maps the influence of five core categories to fourteen attribute-based categories comprising the constituent elements of the decision environment and the resource environment that were of interest to practitioners. The mapping is summarized as sixty-nine testable hypotheses. The data set was sufficiently large to provide replication of major findings, while remaining within time and resource constraints acceptable for graduate thesis research.

Memos were sorted into a framework for presentation, and written up in a format acceptable for a graduate thesis document. The resultant theory was presented in a form that was parsimonious, testable and logically coherent, in accordance with Pfeffer's (1982) criteria for good organizational theory.

Respondent approval was obtained for all quotations included in this document. This provided the opportunity to review key findings with practitioners, and account for practitioner feedback in the final report. Miles & Huberman (1994) recommend respondent feedback as a means to improve the quality of results.

5 Analysis of Results

This section provides an analysis of the results produced by the methods of section 4. First, it begins with an overview of the eight research cases. Second, it presents a summary of the various practitioner beliefs harvested from interview transcripts. Third, it describes the emergent categories and the high-level relationships between each. Next, it describes each category in its own sub-section, along with its properties, emergent insights, and relationships to other categories. Then, it presents a summary of the emergent grounded theory, with a compilation of all emergent hypotheses. Finally, it compares the emergent grounded theory to the practitioner beliefs.

5.1 Overview of Cases

The eight cases are new ventures founded by former employees of Nortel Networks between the years 1992 and 2001. Each venture had either its headquarters or the major development office located in Ottawa Canada. Restricting the study to one parent corporation controlled for entrepreneurial prominence (see section 2.6). Restricting the study to one geographical region controlled for variations in the external climate (see section 5.4.1) and the legal and regulatory climate (see section 6.1).

There is much diversity within the data set. For example:

- Six cases are corporate ventured technology spin-offs (as defined in sections 1.2 and 2.4) that utilized intellectual property developed at the parent corporation; two cases are fully independent start-ups that utilized no parent IP.
- Two cases were incubated within a structured corporate venturing program; two cases were incubated within the parent as semi-autonomous business units; four cases were not incubated within the parent.
- Four cases spun-out with a separation agreement in place with the parent corporation. Two cases were fully independent from the parent and had no separation agreement. Two cases were initially independent, then subsequently completed a separation agreement approximately one year later.
- The parent corporation retained majority ownership of two cases and minority ownership

of two cases; two cases had technology licensing agreements with the parent corporation.

- Six cases were financed by venture capital; two cases initially "bootstrapped" their growth with founder investment and their own revenue.
- One case had an initial public offering of stock; one case was acquired by another firm; one case declared bankruptcy; five cases remain privately held ventures.
- The product and service offerings include electronic hardware products (both semiconductors and hardware subassemblies), software products (both stand-alone applications and components), and business services.
- Five cases supplied a product or service to the parent; one case competed with the parent; two cases entered entirely different value networks.

5.2 Practitioner Beliefs

This section compiles various "practitioner beliefs" that were harvested from the interview transcripts of this study. Each numbered statement documents a generalization or trend that was proposed by one or more practitioners in response to open-ended questions regarding the similarities and differences between spin-off and start-up ventures. For example, if a respondent were to have said, "A spin-off can leverage the supply agreements of a parent," that generalization would be reported here as a practitioner belief. If a respondent were to have said, "Venture B leveraged the parent's supply agreements", that result would be triangulated with other sources and analyzed in sections 5.3 through 5.7.

These statements are not structured as formal hypotheses, nor are they directly tested in this study. Rather, they fully disclose the practitioner biases that may have been imprinted on the researcher during the data collection process. Some of these statements suggest lines of inquiry that were explored in analyzing the case data. However, theory was derived only from the case data itself, not the practitioners' interpretations of that data. The methods chapter (section 4) documents the mechanisms to control researcher bias and keep the theory grounded. In the following sections, emergent theory will be compared back to practitioner beliefs as relevant.

As noted in the literature review (see section 2), the term "spin-off" is not universally defined in the research literature nor among practitioners. Rather than constrain practitioners to

a particular perspective, they were encouraged to use the term as it was generally understood within their professional circles. Where a proposed relationship is exclusive to a specific spin-off subset, such as new ventures that are majority-controlled by a parent corporation, or new ventures that have intellectual property transferred from the parent, that is noted explicitly.

Asterisks denote contention. Any statement marked by an asterisk was directly disputed by at least one practitioner. For example, two practitioners may have proposed a positive correlation between two variables, but a third practitioner proposed either a negative correlation or no correlation at all. Statements without asterisks are not necessarily universally accepted – this simply indicates that no practitioner offered a statement that was directly contradictory under open-ended questioning.

General

1. There is no "typical" spin-off; each situation is complex and unique.
2. At formation, a spin-off will have more assets than an independent start-up, including one or more of people, intellectual property, or customers.
3. At formation, a spin-off is closer to product than an independent start-up. There is less R&D risk.
4. The differences between spin-offs and independent start-ups diminish as the firms mature.
5. Spin-off founding teams tend to be stronger on technical skills and weaker on business skills.
6. At formation, a spin-off is likely to have an established management team that worked together at the parent. This can be advantageous if the team is well balanced or disadvantageous if the team is inappropriate.
7. Most development projects at large corporations are complex and expensive, and thus not suitable for new ventures. Such business plans will not be funded.
8. Running a successful business is different from running a successful technology project within a parent corporation. A spin-off must undergo a significant transformation if it is to survive.
9. The spin-off process of negotiating legal transfer of assets is complex and demanding of both time and resources.
10. A spin-off inherits the branding of the parent.

Ownership by the Parent

11. A parent corporation may have different motivations than other investors. Venture capital investors seek financial returns. A parent may also have strategic goals (using the venture to support their core businesses), and seek to protect their brand value.
12. A majority-controlled spin-off taps into the parent's resources more easily than a

minority-controlled spin-off.

13. A parent's equity share in a spin-off will decline over time.

Governance

14. Ownership by a parent changes the governance of the spin-off. As an investor, the parent will demand representation on the board of directors.
15. Spin-offs introduce formal governance earlier.
16. Spin-offs bring in outside directors sooner.

Power

17. An investor exerts influence through formal positional power and knowledge power.
18. The formal governance model of a spin-off treats all investors equally according to their level of ownership. (Formal Power)
19. A parent corporation is likely to have different knowledge and capabilities than angel or VC investors. This knowledge can help a spin-off be successful. (Knowledge Power)
20. The power of the parent corporation will decline over time as the parent's equity position declines.

Business Model

21. The business model of a spin-off will be constrained by the biases of the executives at the parent corporation. Thus, if a parent corporation is conservative and risk-averse, the business model of its spin-off will tend to be conservative and risk-averse.
22. A spin-off is likely to have a more mature business plan because the founders are able to develop the business plan while collecting a secure salary.

Restrictions

23. A spin-off may have formal and informal restrictions on its behavior.
24. Formal restrictions: The intellectual property technology transfer agreement may include claw-back provisions to protect the interests of the parent firm. Possible claw-back provisions include restrictions on the customer list, limitations on who can acquire the firm, demands of reasonable attempts at commercialization, and minimum requirements for financing.
25. Informal restrictions: After spinning off, a new venture will tend to do things the same ways that it did in the incubator.

Liquidity Alternatives

26. Spin-offs may have fewer options for liquidity by acquisition. They may be unattractive to competitors of the parent, for example, because of IP restrictions or the presence of the parent on the board of directors.

Founder Motivation and Rewards

27. The founders of a start-up receive founder shares that are owned outright; the founders of a spin-off may receive options rather than of founder shares.

28. * Founders of spin-offs will have a lower ownership position at spin-off.
29. * Founders of spin-offs will have a lower ownership position at liquidity.
30. The founders of a spin-off may have a lower personal stake in the success of the venture (less personal investment, on-going salary by parent, safety net).

Culture

31. Spin-off culture will resemble the culture of the parent.
32. Spin-offs will formalize their organizational structures sooner.

Technology

33. A spin-off will have better access to intellectual property.
34. In exchange for IP, the parent firm may demand equity, royalties, or both.

Capital

35. The parent of a spin-off typically does not add to their investment after spin-off.
36. Spin-offs may find it easier to get a first meeting with a venture capital investor.
37. Venture capital investors evaluate all investments through the same selection and due diligence process without favoring either spin-offs or start-ups. A spin-off may have attributes that make it more or less attractive as an investment.
38. Investors will view a spin-off less favorably if there are IP restrictions in place, the involvement of the parent is deemed to be detrimental, the founders have a low personal investment in the venture, or the founding management team is deemed unsuitable.
39. Investors will view a spin-off more favorably if it is closer to product and the involvement of the parent is deemed to be constructive.
40. A spin-off may require fewer financing rounds to reach profitability.

Customers

41. At formation, a spin-off may have a customer base that is transferred from the parent; a start-up likely has no customers.
42. Customers may view a spin-off more favorably. A spin-off may be able to gain access to customers that would not deal with an unproven start-up.
43. A spin-off may be unable to access some customers, particularly competitors of the parent, which would be accessible to a start-up.

Suppliers and Partners

44. A spin-off can leverage the parent's supplier relationships and buying power to get better quality at better prices, reduce the time to negotiate deals, and secure better access to technology. The impact is greater with some technologies (i.e. hardware) than others (i.e. software).
45. A spin-off may have better access to suppliers and partners that would not normally deal with unproven start-ups.

Workforce

46. * The workforce of a spin-off will be more risk-averse.
47. Workforce turnover is higher at spin-offs.

Safety Net

48. Founders operating with a "safety net" (circumstances that mitigate personal risk) are able to create ventures that would not otherwise be possible. Examples of a safety net include:
 - the opportunity to develop and refine a business plan while collecting a secure salary
 - other attractive career options should the venture fail
49. Founders operating with a safety net behave differently than founders that are exposed to a higher level of personal risk.
50. A workforce operating with a safety net (i.e. offers of employment back at the parent firm), has different characteristics that a workforce exposed to a higher level of personal risk.

These practitioner beliefs are compared against the emergent grounded theory in section 5.8.

5.3 Relationships Between Categories

Glaser & Strauss (1967) define a *category* as a high-level concept that captures the underlying patterns in the data, and a *core category* as a category that relates to most other categories, and through these relationships, accounts for most of the ongoing behavior. A category may have *properties*, which are concepts about that category. A category could take the form of a typology, a scale, or a continuum.

Five categories account for differences in the decision and resource environments of this data set. Three categories are common to all new technology ventures – the *external environment*, *financing*, and *technology characteristics*. They are included here for theoretical completeness. Two core categories address the main focus of this study – the differences between corporate ventured technology spin-offs and other new ventures. Those categories are the *separation agreement* between the parent and the spin-off, and the *incubation* environment of the new venture. These are *attribute-based categories* (Christensen et al., 2002) producing a *substantive theory* (Glaser, 1998). That is, the core categories are defined primarily by attributes of the phenomenon.

The decision environment and resource environment are composed of various constituent

elements that represent the main concerns of practitioners. The elements of the decision environment include *governance, power, business model, restrictions, liquidity alternatives, and founder motivations and rewards*. The elements of the resource environment include *access to technology, access to capital, advice, assets, customers, suppliers, workforce, and legitimacy*. (In the general grounded theory terminology of Glaser & Strauss (1967), these elements are also categories)

Each category will be described in its own sub-section, along with its properties, emergent insights, and relationships to other categories. Hypotheses related to each category are summarized at the end of each sub-section. Hypotheses are compiled together in section 5.7.

Figure 5 shows the high-level relationships between categories. Line width indicates the weight of the relationship, where weight is a subjective assessment that considers both the number and the significance of hypotheses.

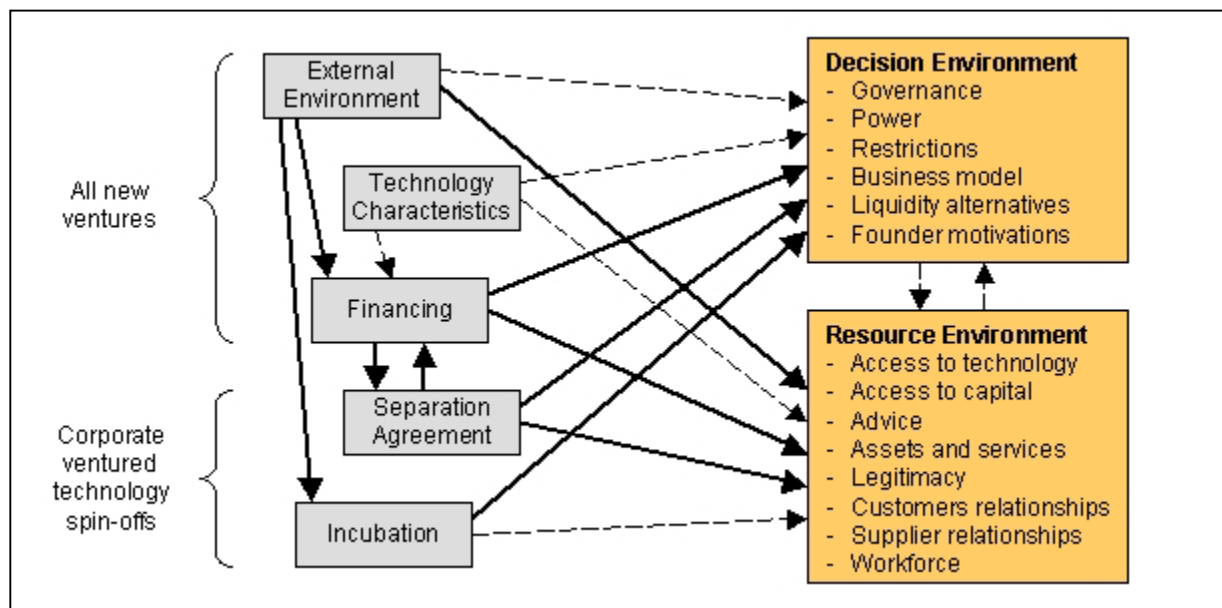

Figure 5: Causal map (summary)

5.4 Core Categories

The core categories relate to the elements of the decision environment and resource environment and account for most of the ongoing behavior.

Three categories are widely applicable to all new technology ventures – the *external environment*, *financing*, and *technology characteristics*. Two core categories are specific to the corporate ventured technology spin-offs in the data set – the *separation agreement* between the parent and the new venture, and the *incubation* environment of the new venture.

The *external environment* includes outside factors over which the founding entrepreneurs have no control. It includes market conditions, regional conditions, and conditions at the parent firm. Cases are clustered into one of three groups according to similar properties.

The *financing* category includes the arrangements by which the new venture secures the capital to fuel its growth. New ventures that receive venture capital financing have many differences from ventures that bootstrap their growth from their own revenues.

Technology characteristics impose constraints on the discovery of a business model for the new venture. Technologies that are fundamentally more resource-intensive have greater demands for capital, talent, and product development cycle time. Sustaining technologies that deliver into an established value network face different challenges than those faced by disruptive technologies that must build new value networks.

The *separation agreement* specifies the legal relationship between the new venture and parent corporation and the arrangements by which the new venture acquires or gains access to the intellectual property of the parent. The parent either exchanges ownership of the intellectual property for equity in the new venture, or licenses access to the intellectual property for a royalty to be paid on sales. Independent new ventures that do not commercialize parent IP have no separation agreement with the parent corporation.

The *incubation* category describes the environment of the venture between formation and either spin-off or completion of the separation agreement. The independent new ventures in this study were not incubated.

5.4.1 External Environment

The external environment includes all the environment factors external to the new venture over which the founding entrepreneurs have no control. It includes the following three factors:

- 1) **Market conditions** in the technology sector and larger economy, including the availability of external capital and the attitudes of the workforce, customer-base, and supply-base;
- 2) **Regional conditions** in the local economy, including local access to venture capital, talent, and support;
- 3) **Conditions at the parent corporation**, including formal policy, attitudes of the executives and staff, the presence or absence of a formal corporate venturing program, and the design and maturity of the corporate venturing program.

Within the data set of this study, it was impossible to isolate the individual contribution of each environmental factor. However, when sorted chronologically (see Figure 6), the cases form three distinct groups that share many common properties.

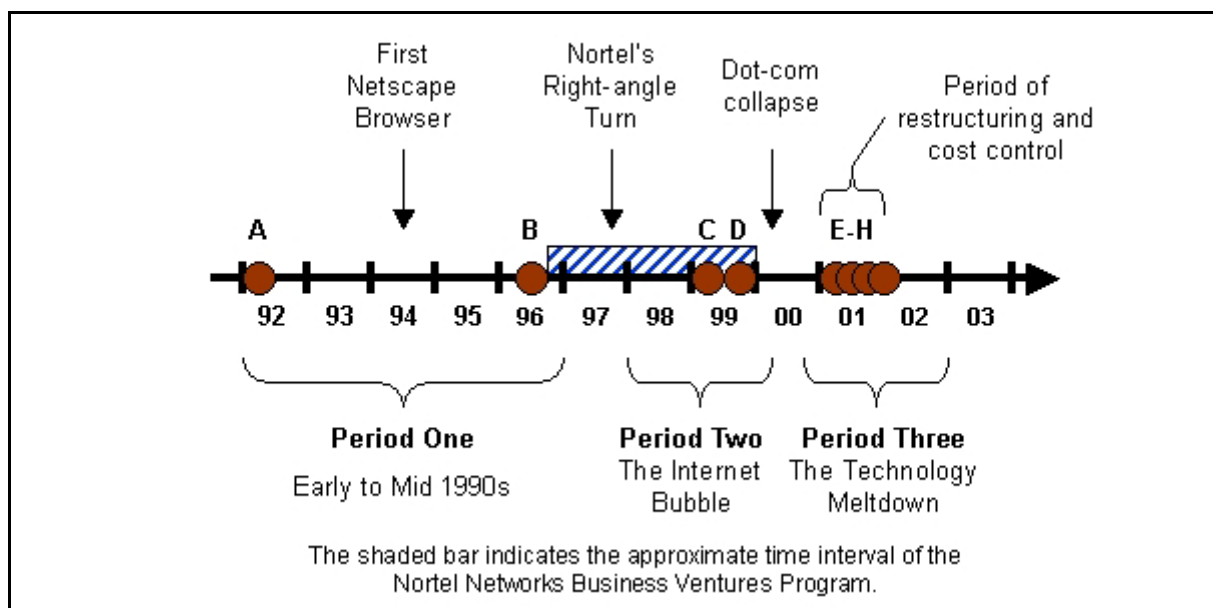

Figure 6: External environment groups

The first group of ventures (cases A and B) was founded in the early to mid 1990s before the explosive growth of the Internet. The second group of ventures (cases C and D) was founded during the technology boom of the late 1990s. The third group of ventures (cases E, F, G, and H) was founded after the technology industry meltdown in 2000. These three time periods, designated period one, period two, and period three, are "fuzzy sets" without crisp boundaries. Even so, each case falls unambiguously into one of the three time periods.

Table 2 summarizes the common characteristics of each *external environment* period.

Table 2: The external environment

	Period 1 (1992-1997)	Period 2 (1998-2000)	Period 3 (2001-2002)
Market conditions	Sustained growth, accelerating in mid-1990s. Growing VC disbursements	Internet boom. Soaring technology stock prices. VC disbursements peak at record levels. Financial markets favor new IPOs. Many firms go public. High evaluations.	Post-bubble, tech collapse. VC disbursements decline. No IPOs. Few acquisitions. Low evaluations.
Regional conditions	Emergence of local technology cluster. Arrival of multinational firms. First local VC offices. First VC fairs with American VCs.	Cluster gains international recognition. Growth rate exceeds that of Silicon Valley. Local VC and seed funding widely available.	Restructuring and workforce reductions at large corporations. Increasing rate of new venture failures. American and local VC disbursements decline.
Conditions at parent corporation	No CV program or CV processes. Each venture opportunity is unique.	Structured CV program. High customer demand. Record revenues. Rapid growth to improve supply. Enthusiasm. High expectations for future growth.	CV program discontinued. Reduced customer spending. Cost cutting. Workforce reductions. Cautious outlook. Extended industry downturn expected.
Other	1994: First Netscape browser	CV research from previous market cycle becomes widely disseminated.	

Background

The Ottawa-Gatineau regional technology cluster (henceforth called the Ottawa cluster) is Canada's largest, most mature, and most widely recognized technology cluster (Ghent-Mallet, 2002). Nortel Networks Corporation is a global supplier of networks and communications services and infrastructure. MacDonald (2000) and Hunter (2002) provide historical accounts.

Period One (~1992-1997)

In April 1991, the American economy entered into a long period of economic expansion following a relatively mild recession (Stiglitz, 2003). It was a period of deregulation, globalization, technological convergence, and growing data traffic on telecommunication networks (Alcalay, 2003). In the early 1990s, technology advances and the changing regulatory framework began to transform the Internet from a niche technology to a major new market for business and commerce (Segaller, 1998). In October 1994, Netscape released the beta version its first web browser, which became the most rapidly assimilated product in history, with a base of 65 million users eighteen months later. Netscape's initial public offering in August 1995 became the first great Internet success story, creating substantial wealth for its founders and investors, and inspiring other entrepreneurs (Nesheim, 2000). Encouraged by growth in the equity markets, and an increasing supply of available risk capital from investors, venture capital disbursements began to climb (Gompers & Lerner, 2001a).

After several decades of incubation and quiet growth, the Ottawa region began to exhibit traits of a strong technology cluster (Ghent-Mallet, 2002). The region attracted about 30% of Canadian federal R&D spending, fueling innovation in the public and private sectors. Large foreign corporations began to establish a presence in the Ottawa area, either by acquiring local firms or opening new offices. The local agglomeration economy favored technology investment, particularly relating to telecommunications technology.

At Nortel Networks (then called Northern Telecom Limited), revenues were mainly from voice telephony equipment sales to established telecom carriers. The Nortel business model was structured to service the value network of these customers with highly reliable product, which required multi-year development cycles and extensive testing (MacDonald, 2000).

Period Two (~1998-2000)

North American economic growth and productivity increases accelerated in the mid-1990s (Stiglitz, 2003). From 1995 to 2000, U.S. venture capital disbursements soared, growing by at least 32% every year. Disbursements in 1999 and 2000 were US\$56B and US\$107B respectively, compared to disbursements of US\$2B in 1991. Financing terms favored the entrepreneur, with less restrictive partnership agreements, larger and more frequent investments in portfolio firms, and higher valuations for investments (Gompers & Lerner, 1999, p. 326).

The Ottawa region gained international recognition as a world-class technology cluster. Throughout the 1990s, Ottawa had been the fastest growing technology region of Canada, with a growth rate exceeding that of Silicon Valley in the United States (Ghent-Mallet, 2002). According to Doyle (2002), at the end of 2000, the region was home to approximately 1350 technology companies employing approximately 74 000 people. The first local venture capital offices were established in Ottawa in the mid-1990s, including regional offices for Canadian-based funds and main offices for new Ottawa-based funds that planned to invest primarily in the Ottawa region. Access to local offices significantly improved the availability of risk financing to Ottawa companies (see section 2.5.2). The Ottawa Capital Network held its first annual Venture Capital Fair in 1997, attracting participation and attention from American VCs based in California and Boston.

In 1997, data traffic on public communication networks exceeded voice traffic for the first time. In December, new CEO John Roth responded by announcing the "Webtone" vision that would transform Nortel from a telephone equipment supplier to an aggressive architect of the Internet (MacDonald, 2000). Corporate technology development shifted away from in-house development to growth by acquisition, with a focus on achieving first to market. Between November 1997 and June 2001, Nortel acquired 18 other ventures – mostly start-ups – valued at more than US\$30B. Nortel's business model transformed to compete against data networking suppliers, particularly Cisco, and target new market entrants – competitive carriers, Internet Service Providers (ISPs), and competitive local exchange carriers (CLECs) (Bagnall, 2002).

In 1996, Nortel formed a corporate venturing initiative called the *Business Ventures Program* (Colarelli O'Connor & Maslyn, 2002; Lieber, 2000; Leifer et al., 2001). The program

reviewed nearly three hundred employee-submitted proposals and placed twenty-eight seed investments. It produced three external spin-offs, one external licensing agreement, and five "spin-in" ventures that were integrated back into Nortel lines of business. Based on the methods of venture capital investors, the BVP included a selection process, a governance framework, and a business incubation environment. Nortel also spun-out two other ventures in 1998 independently of the Business Ventures Program. The program was disbanded in late 1999.

Period Three (~2001-2002)

After a meteoric rise, the dot-com sector collapsed in April 2000. Falling market evaluations of Internet companies dropped the NASDAQ technology index by 1500 points during the first two weeks of the month from a high of over 5000 points in mid-March.

Venture capital disbursement declined sharply in 2001 and 2002. With declining supply of risk capital, financing terms shifted back to favor the investor rather than the entrepreneur, with more restrictive partnership agreements, smaller and less frequent investments in portfolio firms, and lower valuations for investments. U.S. venture capital disbursements were approximately US\$41B and US\$21B in 2001 and 2002 respectively. Investment levels in 2002 were comparable to those of 1998 (PricewaterhouseCoopers, 2003).

The local Ottawa economy responded to the technology meltdown by forming more than two hundred new start-ups in 2001. Some analysts have compared the proliferation of Ottawa start-ups in the wake of layoffs in the telecommunications sector as being akin to the breakup of Fairchild Semiconductor in the 1960s (Thompson, 2002) – a significant event in the history of Silicon Valley that led to the formation of Intel, AMD, National Semiconductor, and LSI Logic, which in turn led to the formation of many other technology firms.

Nortel revenues remained strong until October 2000, when growth in the sale of optical systems began to slow. At year-end 2000, the company had a global workforce of 95,000 employees, with 16,000 based in Ottawa. In 2001, Nortel announced four separate restructuring plans to reduce the workforce and control spending. By 2002, Nortel had streamlined operations with a workforce of approximately 37,000, including 6000 positions in Ottawa (Nortel Networks, 2003), with a business model focused on sales to established telecom providers.

In summary, the external environment impacts financing (H1), incubation (H8), liquidity alternatives (H33), founder motivations (H37), the supply of capital (H42), advice from investors (H49), access to customers (H59), and the characteristics of the workforce (H68).

5.4.2 Technology Characteristics

Different technologies have widely varying requirements for capital, knowledge, and the time to design a new product and deploy it to the market. In addition, products and services may deliver into markets and value networks at different degrees of "newness". Mature markets with a dominant design (Abernathy & Utterback, 1978; Utterback, 1994) may have established market channels with expectations of certain business models. Imposing an unfamiliar business model on a mature channel may be time-consuming and expensive. All of these forces may combine to constrict the process of business model discovery (see section 2.7) for a new venture. In contrast, the process of business model discovery to commercialize an innovation for which there is no established value network may require a higher investment of resources and time and have an unmitigated high probability of failure.

The two properties of this category are the *resource intensity* of the technology (a relative scale between a *high* demand and a *low* demand for resources), and the *type of innovation* (*disruptive* or *sustaining*). Each property is developed below.

Commercialization of some technologies is more demanding of resources than the commercialization of other technologies. For example, the development of a new product with both hardware and software may require higher investment and a longer product development cycle than the development of a new software application. The hardware product may require design and fabrication of new ASICs (application specific integrated circuits), the design, fabrication and assembly of circuit boards, mechanical packaging, and so on. In comparison, a software application could be distributed either electronically or on a physical medium for execution on an existing hardware platform. The former product would be termed *high* resource intensity while the latter would be termed *low* resource intensity. This property is consistent with Nesheim's (2000) observation that there are differences between the characteristics of hardware, software, and Internet start-ups.

Christensen's (1997, p. xv) framework of disruptive and sustaining innovations is a useful

property of this category (this research is discussed from different perspectives in sections 2.1, 2.5.3 and 3.2). *Sustaining* technologies, whether discontinuous, radical or incremental in character, all foster improved product performance when delivering into existing value networks. *Disruptive* technologies initially result in worse product performance in mainstream markets, but bring to market a different value proposition that may be appealing to fringe customers. Disruptive technologies on a sufficiently steep technology trajectory (Dosi, 1982) may eventually become competitive in mainstream markets.

In summary, technology characteristics impact financing (H2), the process of business model discovery (H29, H30), demand for capital (H43), legitimacy (H56), and access to suppliers (H64).

5.4.3 Financing

A large body of research on venture capital, as surveyed by Gompers & Lerner (1999a, 2001a), Callahan & Muegge (2003), and briefly in section 2.5.2, supports the notion that start-ups financed with venture capital have many differences from other start-ups. The specific mechanisms of causation are less clear. Some differences are thought to be the direct result of investor intervention in the new venture. Others are thought to result from the venture capital selection process that favors firms with certain attributes. Regardless, many of these differences fall within the scope of the decision and resource environments.

The financing category is included here for theoretical completeness. It was not an intended focus of the study, and the findings reported here replicate rather than extend extant theory. Nonetheless, the category is necessary to account for differences between the decision environment and resource environments of the six *VC-backed* ventures (cases B, C, D, E, and G) and the two ventures that *bootstrapped* their growth from their own revenue (cases A and F).

Figure 7 shows the growth model of an independent VC-backed new venture. This model serves as a benchmark for comparison of the spin-off formation models that will be described in section 5.4.5.

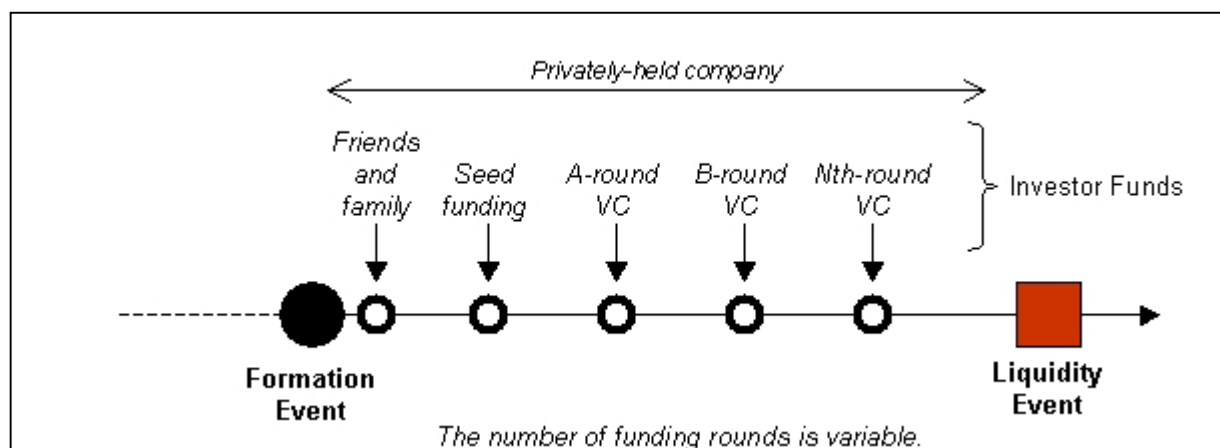

Figure 7: Growth model of a VC-backed new venture

The *formation event* was the moment when an idea became a new business venture. It may have corresponded to the date of legal incorporation of the business, a particular meeting of the founding team, or a decision to commit founder resources to the venture. When asked about the founding of their venture, all founder respondents designated a particular moment in time that represented the formation event of their venture.

After formation, the new venture required a series of *financing events* to secure the investment capital required to grow the business. A typical growth model had several funding rounds, possibly including founder investment, a "friends and family" funding round, a seed funding round, and three rounds of venture capital. Many variations were observed, with most new ventures excluding at least one of the funding rounds shown in Figure 7. Each funding round provided sufficient resources only to achieve specific milestones and reach the next round of financing.

Shares of the privately held new venture were normally very difficult to buy or sell. Shareholders could effectively exit their investments only at a *liquidity event* – an IPO, acquisition, or bankruptcy. At an IPO, the new venture became a publicly traded company with shares that were bought and sold on the public markets. At an acquisition, the new owners bought-out the ownership stake of previous investors with cash or new stock. At a bankruptcy

event, investors recouped some fraction of their investment through the liquidation of assets. Regardless of the specific circumstances of the liquidity event, it provided investors with the opportunity to exit the investment taking profits or losses. Five of the cases had not yet experienced liquidity events.

Financing milestones paralleled the achievement of other business milestones across a broad spectrum of categories. One financial consultant explained the relationship as follows:

"In the internet bubble period, companies secured financing to buy eyeballs and burn cash, and if they did that successfully they got more cash.

Today, milestone achievement drives the financing, not the other way around. You have to show traction in those areas of the business that are most important to creating value before you are going to get money. I have a checklist of five things that I evaluate: technology, product, market, organization and finance. A company needs to achieve milestones in all of those areas, and those milestones will change over time. Financing is an important area, but it's only part of the equation."

Data on technology, product, market, and organization were also collected for all cases. Upon analysis, however, a simple growth model based on financial milestones was adequate to account for the observed diversity of the data set.

One entrepreneur likened growing a business to driving a car. In this analogy, each round of venture financing was a gear on the car's transmission. Once the engine was revving sufficiently high, the driver could shift into the next higher gear.

Some new ventures were able to raise a high level of early financing through other channels (such as personal savings, friends and family, private angel investors, or cash provided by a corporate parent) and generate early revenues from sales of products or services to *bootstrap* their growth without venture capital financing. Alternately, a venture could bootstrap its early growth, then seek late-stage external financing in order to prepare for a liquidity event. The growth model of bootstrapped ventures was similar to that of Figure 7, without the venture capital financing events. As with the VC-backed growth model, the bootstrapped growth model paralleled other business milestones that are not shown.

The new venture growth model developed here is complementary to various published models of new venture growth in the management literature such as those of Callahan & Muegge

(2003), Nesheim (2000), and stage-growth model of Kazanjian (1988).

As discussed in section 5.4.1, the external environment had a strong impact on the availability and terms of financings. The supply of venture capital financing was much greater for new ventures during the Internet bubble of period two, and much reduced during the technology meltdown of period three.

Two founders cited strong differences between their American and Canadian venture capital investors. By both accounts, American VCs had more aggressive expectations and were more tolerant of higher levels of risk. They sought higher targets. They were more receptive to, and in one case more demanding of, changes to strategy during periods of crisis. This observation is noted here as an interesting insight for further study.

In summary, financing is related to the external environment (H1) and technology characteristics (H2).

H1: The availability of venture capital financing during period two was greater than the availability of venture capital financing during period one, which was greater than the availability of venture capital financing during period three.

H2: New ventures commercializing resource intensive technologies require high levels of financing. Such high levels of financing are difficult to bootstrap.

Financing impacts the separation agreement (H3, H6, H7), governance (H9, H10), power (H17, H18), the process of business model discovery (H31), liquidity alternatives (H34), founder motivations (H38), the supply of capital (H44), advice (H50), external legitimacy (H57), access to customers (H60) and access to suppliers (H65).

5.4.4 Separation Agreement

All eight case study ventures were founded by former employees of the same parent corporation. However, the ventures had different legal relationships with the parent, and different arrangements regarding ownership and licensing of intellectual property.

The two properties of this category are parental *ownership* and *licensing* arrangements with the parent corporation. Both properties represent what the new venture provides back to the parent in exchange for ownership of, or access to, intellectual property that was controlled by the

parent.

Four cases were partially owned by the parent corporation. Two new ventures were initially *majority-controlled* (cases B and D). At the time of spin-off, the parent corporation owned more than 50% of the voting rights in the majority-controlled ventures. Two other cases were *minority-controlled* (cases C and E): At the time of spin-off, the parent corporation retained some voting equity in these new ventures, but that ownership position was less than 50%. In exchange for equity in the new venture, the parent transferred ownership of relevant intellectual property to the venture.

The parent corporation did not invest additional funds in any ventures after spin-off. Thus, the parent's ownership position became diluted over time with each new round of external financing, and the majority-controlled ventures later became minority-controlled. One venture capital investor explained the parent's motivations as follows:

"The parent's investment in a spin-off is the Intellectual Property they contribute. The money to develop that IP is already spent, and they've already claimed their R&D tax credits. Perhaps the IP would just sit on the shelf if a spin-off didn't run with it. A parent could put ten million dollars of IP development into a spin-off without spending any new money. A venture capital investor who puts in ten million dollars is more motivated to grow the company to the point where they can get their money out. It's their main business."

This view is consistent findings with the findings of the literature survey on participant motivations (section 2.5).

Two other ventures (cases A and F) had technology licensing agreements with the parent corporation. These new ventures entered into contracts that provided them with access to intellectual property that was owned by the parent. The specific terms of a licensing agreement may vary widely, possibly including royalty payments on product sales and specific terms under which the ownership of the IP would be formally transferred to the new venture. One licensing agreement, for example, had a seven-year duration. Following a two-year grace period, the new venture was required to pay the parent corporation a royalty on each product sale. The royalty declined each year after year three, going to zero at the end of year seven. At the end of the licensing period, ownership of the IP transferred from the parent to the venture with no restrictions.

Two other ventures (cases G and H) were fully independent. These ventures did not commercialize IP from the parent corporation and thus did not require a separation agreement with the parent. Their connection to the parent was one of genealogy only.

Figure 8 provides a pictorial illustration of the properties of the separation agreements of the six corporate ventured technology spin-offs. The two fully independents without separation agreements are not shown. In principle, it is conceivable that a new venture could have both a licensing agreement and an equity ownership relationship with the parent corporation. However, no examples of that were discovered in this study.

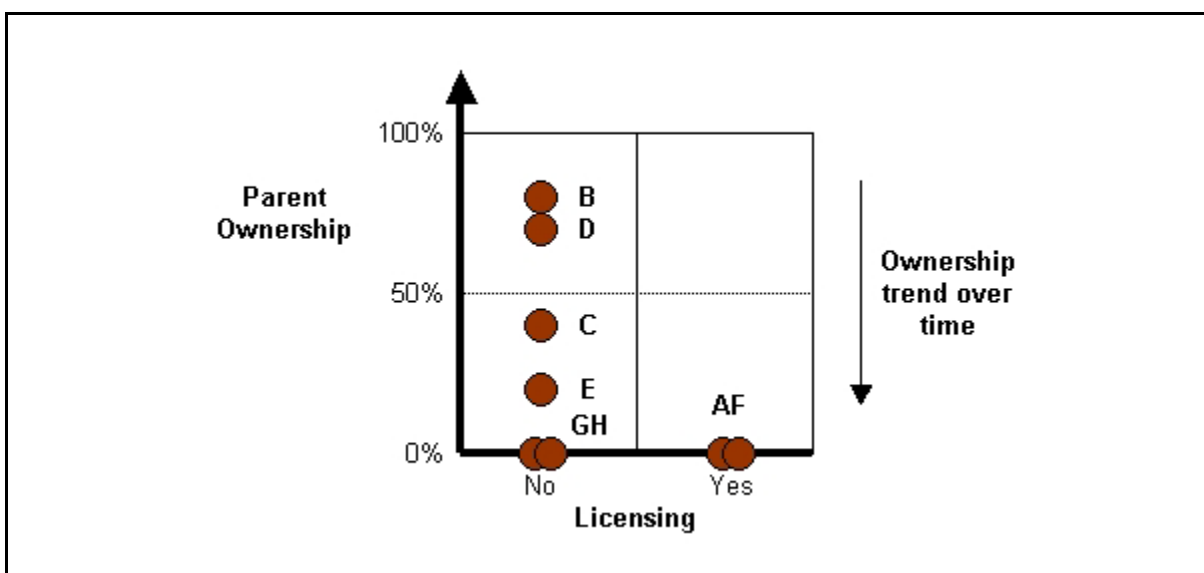

Figure 8: Separation agreements of case study ventures

The separation agreement for a particular new venture was related to the source of new venture financing and the specific nature of the parent's interest in the new venture. Each relationship is explored separately below.

Both licensed ventures (cases A and F) spun-out with a revenue-generating product and chose to bootstrap their growth. Neither venture had major external investment; both were financed primarily by founder, and "friends and family" money. In contrast, the four ventures with parental ownership (cases B, C, D, and E) all secured external financing to coincide with

their spin-off from the parent corporation.

The properties of the separation agreement also reflect the parent's interests in the new venture. In some instances, the parent may have opted for minority rather than majority ownership in order to reduce their potential liability should the venture be perceived as a failure.

A founder of Venture C recalls:

"Nortel did not want to be the majority shareholder. Being the majority shareholder could make them liable for various things should we not be very good community citizens. They didn't want that liability."

Licensing agreements may be appropriate for strategic investments that are not intended to generate large financial returns. A founder of Venture A explains:

"At Nortel, the revenue cut line for approving a new product proposal was in the hundreds of millions of dollars within two years of going to market. The only reason for Nortel to bother commercializing this technology was to provide value to its own engineers. The potential revenue from us wouldn't have paid for the peanuts on the corporate jets."

In summary, negotiating the separation agreement requires a sizable commitment of time and effort by both the founding entrepreneurs and the parent corporation (H5). Parent ownership declines over time as the parent's investment becomes diluted, unless the parent provides follow-on investment (H4). The separation agreement is related to financing (H3, H6, H7).

H6: A parent corporation may be more willing to enter into a separation agreement involving parental ownership and the transfer of IP ownership with new ventures that have secured venture capital financing. In some instances, the spin-off event may be contingent of securing VC financing.

H7: VC investors actively participate in the negotiation of the separation agreement. Spin-off events and announcement of venture capital financing often coincide.

The separation agreement impacts governance (H11, H12, H13), restrictions (H25), liquidity alternatives (H35), access to technology (H40, H41), advice (H51), legitimacy (H58), access to customers (H61, H62), access to suppliers (H66), and the workforce (H69).

5.4.5 Incubation

This category describes the climate in which an embryonic new venture is nurtured. As described in section 5.4.3, most independent new ventures enter immediately into a continuous financing cycle (Nesheim, 2000; Gompers & Lerner, 1999a), using the capital raised from each funding round to accumulate the resources to grow the business to the next step, while raising the next funding round. Alternately, some new ventures are initially sheltered by the parent corporation in an internal corporate incubator that provides them with some services and resources. The most successful of these incubated ventures eventually spin-off from the parent, with most seeking external financing. Other new ventures followed a hybridized "start-up spin-off" growth model. These ventures were founded with some limited support from the parent corporation, but no incubation and no formal separation agreement. They were on their own to raise financing and accumulate resources while they negotiated the terms of the separation agreement with the parent corporation.

Corporate incubators are one element of a larger family of possible incubation strategies, including publicly funded incubators that are sponsored by governments, and private for-profit incubators that provide services in exchange for equity (Tübke & Empson, 2003; Richards, 2001; Hansen, Chesbrough, Nohria & Sull, 2000; Rice & Matthews, 1995). None of the ventures in this study were incubated in either publicly funded or for-profit incubators. The impact of other incubator environments on the decision and resource environments of new ventures was not within the scope of this study.

Two cases in this study (cases G and H) were fully independent ventures with no separation agreement and no incubation by the parent firm. These cases followed the growth model of Figure 7, previously described in section 5.4.3.

Four cases (cases A, B, C and D) followed the corporate incubation growth model illustrated in Figure 9. While this model has many similarities to the growth model of an independent VC-backed start-up (see Figure 7) described in section 5.4.3, it also differs in several important characteristics.

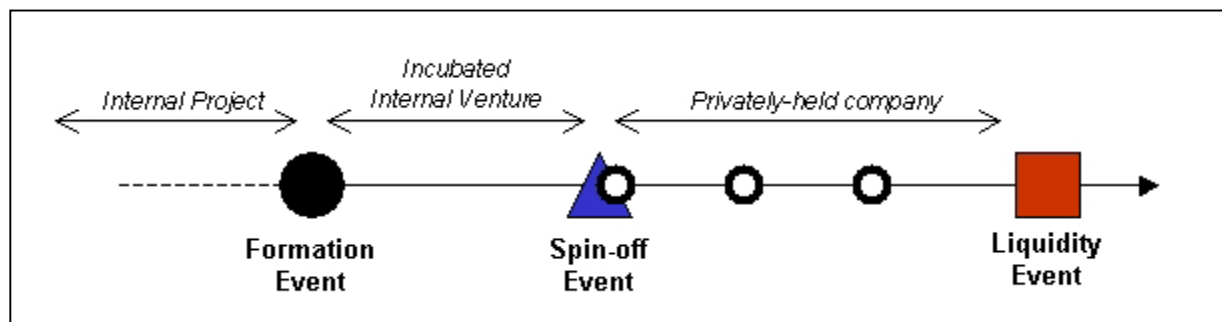

Figure 9: Growth model of a spin-off from a corporate incubator.

The *formation event* was the moment that an internal corporate project transitioned to a corporate-incubated internal venture. For all four of the internally ventured cases in this study, the formation event was easily characterized; internal projects and incubated internal ventures were very distinct. Internal projects were managed and funded by a corporate business unit. Internal ventures were managed and funded as either semi-autonomous organizations or within the umbrella of a corporate venturing program. Compared to internal projects, internal ventures received different treatment by the parent corporation, and were evaluated by different metrics.

The *spin-off* event was the transition from an internal venture to a privately held company under the terms of the separation agreement (see section 5.4.4). The spin-off event involved some transfer of assets, possibly including staff, intellectual property, and physical assets. After spin-off, the new venture joined the financing cycle with other start-ups. As with independent new ventures, it could bootstrap its growth from founder investment and revenues, or compete for attention from venture capital investors (see section 5.4.3). In some cases, the parent and the internal venture previously arranged venture capital financing to correspond with the spin-off event. While in the incubator, internal ventures grew their businesses by completing milestones related to technology, product, market, and organization. As a result, incubated spin-offs emerged from the incubator with more mature businesses that required fewer financing events to reach a liquidity event. Being further along in the product development cycle, incubated ventures had lower technical risk related to R&D uncertainty. Some incubated ventures spun-out with first-release product and established customer lists.

Two incubated cases (cases C and D) were nurtured within a *structured incubator*. The structured incubator was managed within a corporate venturing program that included a selection

process, a governance framework, and a business incubation environment. The two cases in this study spun-out through the Nortel Networks Business Ventures Program (see section 5.4.1).

Two other incubated cases (cases A and B) were nurtured within an *informal incubator*. Ventures within this group were managed within the parent corporation as semi-autonomous business units. Each was managed independently. They were not incubated together as part of a structured corporate venturing program.

Two other cases were neither independent new ventures nor incubated corporate ventures. These cases (cases E and F) followed the hybridized growth model shown in Figure 10. One investor practitioner labeled these ventures as "*start-up spin-offs*" to distinguish them from incubated spin-offs. Both sought to commercialize discontinued projects that the parent had shut down during a period of restructuring and consolidation. The founders were on friendly terms with the parent corporation, and received some limited parental support, but without a formal separation agreement for access to intellectual property controlled by the parent. Executive supporters within the parent corporation did offer assurances that the parent would be interested in entering into a separation agreement once certain business milestones had been achieved. Like the independent ventures of Figure 7, these ventures needed to raise their own risk capital through conventional channels. While raising capital and growing the business, they continued to negotiate the terms of the separation agreement with the parent. Separation agreements were completed approximately one year (eleven months and sixteen months respectively) after the formation event.

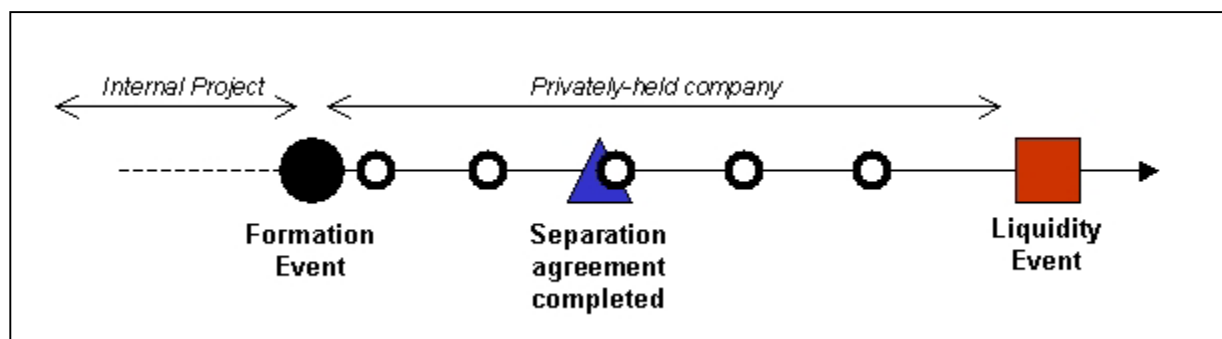

Figure 10: Growth model of a "start-up spin-off" – an external corporate ventured spin-off

The incubation category is related to the external environment category (see section 5.4.1), particularly to the corporate venturing policy within the parent corporation. Not all incubation environments were equally available at all times. During period one, there was no general corporate policy at the parent corporation regarding corporate venturing; each corporate venturing opportunity was treated separately. There were no standard processes or procedures to spin-out a new venture. Both period one cases had the active support of an executive champion. All ventures spun-out of the parent corporation during period one emerged were nurtured in an informal incubator.

During period two, the parent corporation created the Nortel Networks Business Ventures Program (Colarelli O'Connor & Maslyn, 2002; Lieber, 2000; Leifer et al, 2001), a structured corporate venturing program that included a selection process, a governance framework, and a structured business incubation environment. The program was centrally managed by a dedicated organization called the Business Ventures Group. As well, some business units within the parent corporation continued to informally incubate and spin-out ventures independently of the Business Venture Group. Period two produced corporate ventured technology spin-offs from both structured incubator and informal incubator climates. Both period two cases selected for inclusion in this study were incubated through the Business Ventures Program.

During period three, the parent focus was one of cost reduction and consolidation. Discussions with practitioners did not identify any group three spin-offs that received corporate incubation.

The incubation category is independent from the separation agreement category described in section 5.4.4. Ventures from any of the incubation climates (structured, informal, or start-up spin-off) could have separation agreements based either on parent ownership or technology licensing. As shown in Figure 11, the data set of this study included internally incubated cases with parent ownership, and an internally incubated case that licensed technology from the parent, an external "start-up spin-off" corporate venture with parent ownership, and an external "start-up spin-off" corporate venture that licensed IP. Although both cases from the structured incubator had parent ownership, the same incubator is known to have arranged a licensing deal that was not included as a case in this data set.

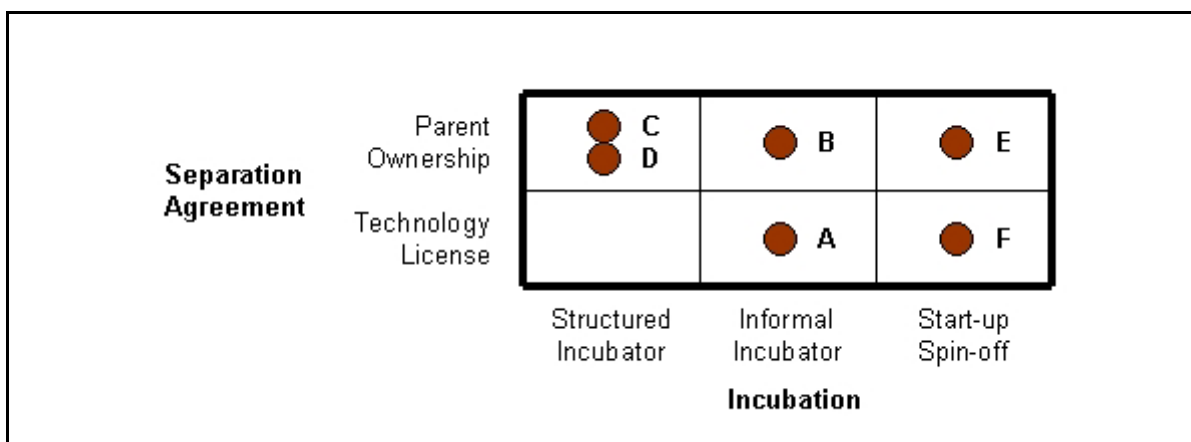

Figure 11: Orthogonality of the separation agreement and incubation categories

Published literature on corporate incubators suggests that their functions are to increase the likelihood of new venture success (Tübke & Empson, 2003; Richards, 2001; Mason & Rohner, 2002) and to discourage employees from leaving to found independent start-ups (Hellmann, 2003; Barry, 2000). This study suggests a third function – that a corporate incubator provides a parent corporation with an opportunity to engage in corporate venturing while mitigating the risk of damage to its brand value and reputation.

Corporate risk management was a frequently cited theme by interview respondents discussing the origins of incubated spin-offs. One founder explained that to a large corporation, the downside potential of doing a spin-off was greater than the upside potential. Often, the upside could be a contribution to shareholder value by generating financial returns for the corporation. That contribution was likely to be modest in comparison to the revenues of the corporation's established business units. The downside could be a negative impact on the revenue from those established businesses by damaging the corporate brand value. The downside impact of damaging even a single established customer relationship of the parent could be greater than the spin-off's revenue potential. While a venture capital investor is mainly concerned with financial upside, a corporate venturing parent is concerned with both financial upside and potential downside. Venture capital investors expect most investments to fail (Gompers & Lerner, 1999a). Their potential loss is no greater than the time and resources

committed to that venture. The parent's exposure to risk extends beyond the parent's investment to the spin-off.

By many accounts, the parent sought a high level of confidence that an internal venture would survive and be successful before approving it for spin-off. One founder recalls how the Venture Advisory Board rejected his venture three times for spin-off:

"We had a great technology. We validated the market with two large customer proof points. We had a reasonable business plan. I wanted to spin it out and do it. The corporate venture group wanted to see more data first to prove that the business model was right. I said, 'That's what VC money is for!' It went back and forth."

The spin-off was approved after two venture capital investors committed to back the venture contingent on completion of the separation agreement. Partners from the VC firms actively joined the negotiations.

Corporate incubators effectively allowed the parent to encourage entrepreneurship while retaining control. If the balance between upside potential and downside potential did not match the parent's investment objectives, the internal venture would not be allowed to spin-off.

This risk management function was institutionalized in the structured incubator. The venturing pipeline was funnel-shaped. Of the 300 proposals received, 28 investments were seeded, 11 were incubated, and 9 were migrated out of the program. It managed risk through the same mechanisms as the product development pipeline of Wheelwright and Clarke (1992) or the deal flow pipeline of venture capital investors (Callahan & Muegge, 2003) – by enabling many low-risk high-uncertainty early stage investments and allowing only the best to proceed.

In summary, incubation is related to the external environment (H8).

H8: A structured incubator is only available within a corporate venturing program. For the data set of this study, the parent corporation established a corporate venturing program during period 2.

Incubation impacts governance (H14), the distribution of power (H19, H20, H21), restrictions (H26, H27), founder motivations (H38), advice (H52), assets and services (H53), and legitimacy (H55).

5.5 Decision Environment

The relationship between the core variables and the elements of the decision environment is shown in Figure 12 below. Each arrow represents one or more testable hypotheses that are developed in the following subsections and compiled in section 5.7. The relationships between core variables, and between elements of the decision environment and resource environment, are not shown in the figure.

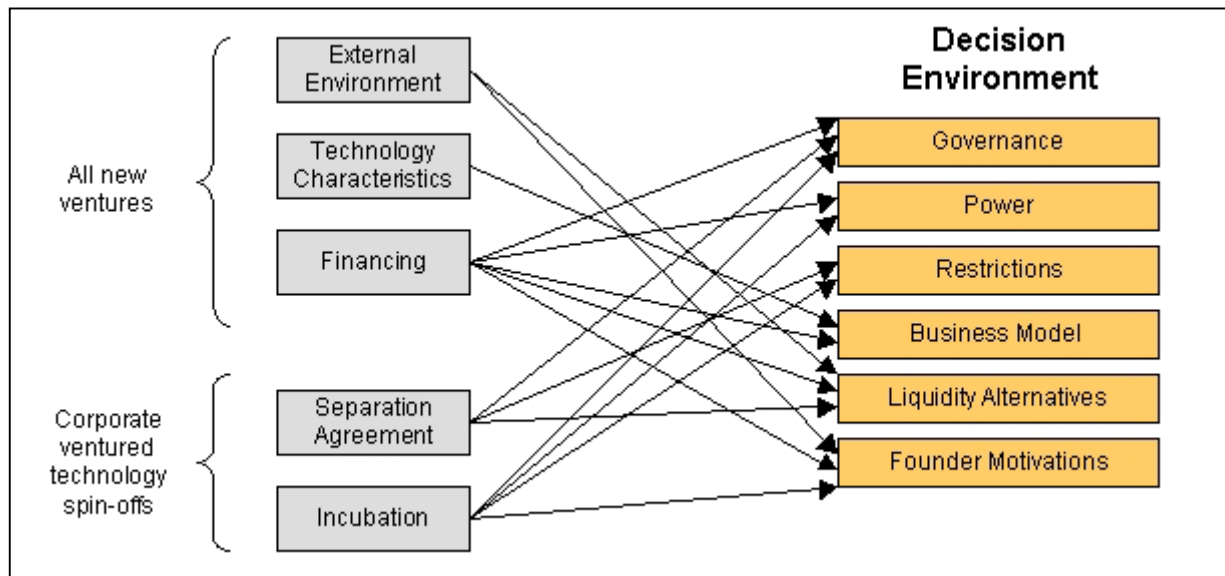

Figure 12: Factors influencing the decision environment

5.5.1 Governance

The governance category includes the formal governance structure of a new venture, and the changes within that structure over time. Governance is described more thoroughly than other elements as an example of the process of emergent hypothesis discovery described in section 4. Both an expanded tabular display (Table 3: Expanded tabular display of governance properties.) and sample causal map (Figure 13: Causal map of selected governance) are included in this section. The descriptions of other elements, particularly the processes of emergent discovery, are less detailed, consisting mainly of the presentation of emergent results.

Corporations are required by law to form governance structures (Colley, Doyle, Logan & Stettinius, 2003). Though the details of corporate law do vary between regions (established by state governments in the U.S. and provincial governments in Canada) there are many commonalities. The three elements of governance are the shareholders, the board of directors, and the chief executive officer (CEO) of the corporation (Montgomery & Kaufman, 2003). Shareholders elect and can replace the board. The board derives power from the shareholders to mitigate potential conflicts of interest between investors and corporate management. The CEO reports to the board the board of directors, and as a matter of practice, the board delegates most decisions to the CEO (who delegates power to other managers). The responsibilities retained by the board of directors typically include hiring, evaluating, and firing the CEO, setting compensation for the CEO, monitoring performance of the firm, and advising on and approving major policy decisions (Sonnenfeld, 2002). The powers and structure of the board are articulated in a corporation's governing documents, including articles of incorporation, corporate bylaws, and shareholder agreements (Colley, Doyle, Logan & Stettinius, 2003).

For an early stage company without outside investors, the board of directors may be the same as the team of founding entrepreneurs. A board meeting may be little different from any other meeting of the senior management team. At that point in the growth model, the energy of the founders is focused on growing the business, and there is little value in added structure or formality. As the investment structure becomes more complex, the board may become more formal, with outside directors, corporate bylaws, and formal subcommittees. This could occur soon after incorporation or much later depending on the interests of the founders and the

demands of the shareholders. Each founding entrepreneur was able to designate a particular point in time when the board of directors transitioned from an informal group based primarily around the founders to a formal corporate governance structure.

The board of a private venture is typically composed of the CEO, directors nominated from the venture's major investors, and possibly independent directors. A particular board member may have voting privileges or observer status as determined by the shareholders.

The legal obligations of a director are legally defined according to duties, with the major duties being fiduciary duty, the duty of loyalty, the duty of fair dealing, the duty of care, the duty not to entrench, and the duty of supervision (Colley, Doyle, Logan & Stettinius, 2003). An experienced investor explained the obligations of a director as follows:

"When you're a director on the board of a company, your only responsibility is to that company. You would be in breach of your duty if you represent anything else other than the interests of that company and the interests of all investors. A board member may be nominated from a certain group, but once you are a director, your responsibility is to the company. If it looks like you're making decisions that are at odds with the company's interests, that may somehow preferentially affect the interests of your investment group, then you're in breach of your responsibilities and you're in dangerous territory. This distinction is often a point of confusion for directors of early stage companies."

By law, the fiduciary duty of a director demands that they pursue the interests of the business in all matters. This can create a complex situation for a director nominated by a strategic investor – such as a corporate parent that invests in a spin-off to improve the performance of an internal business unit. The possible motivations of a strategic investor were previously surveyed in sections 2.5.2 and 3.3.

Table 3 summarizes the governance structures of the case study ventures, and provides an example of an expanded tabular data display used to formulate hypotheses (see section 4).

Table 3: Expanded tabular display of governance properties.

Separation Agreement	Case	Incubation	Governance Characteristics
Majority	B	Informal	Formed a board of directors at spin-off as a majority-owned subsidiary of the parent. At IPO, twenty months later, there were five seats on the board – the CEO, three nominees from the parent corporation, and one major investor.
Majority	D	Structured	An internal venture board formed at incubation, then transformed into the first board of directors when the firm spun-out fourteen months later. The first board of directors had five seats – the CEO, two nominees from the parent corporation, and two major investors.
Minority	C	Structured	An internal venture board formed at incubation, then transformed into the first board of directors when the firm spun-out seventeen months later. The first board of directors had five seats – the CEO, two nominees from the parent corporation, and two major investors. At B-round financing nine months later, an additional director was nominated from the new VC investor.
Minority	E	Start-up spin-off	Formed a board of directors at A-round financing and completion of the separation agreement, eleven months after formation. The first board had five seats – the CEO, three major investors, and advisory (non-voting) nominee from the parent corporation. An additional investor was added six months later, and an external director was added eight months after that.
Licensing	A	Informal	Formed a board of directors three years after formation. The board began to serve a strong function after an experienced outside director became chairman approximately one year later.
Licensing	F	Start-up spin-off	Expecting to form a board of directors approximately thirty-two months after formation.
None	G	None	Formed a board of directors at seed-round financing, four months after formation. The first board had seven seats – the CEO, the CFO, three independents (an angel investor and two nominees from a partner firm who was a major investor), and two advisory (non-voting) nominees from two seed investment firms. After the A-round closed eleven months later, the CFO and one partner nominee resigned their seats. The board then had seven seats – the CEO, four VCs, and two independents (the angel investor and one nominee from the partner firm). A fifth VC was added after an extension round closed three months later.
None	H	None	Formed a board of directors at incorporation. The first board had five seats – the five founders. After A-round financing two months later, two VC investors were added to the board. Eight months later, a new CEO joined and took firm control of the board of directors. At the B-round financing 4 months later, the board had five seats – the CEO, a VP, and three investors.

All cases where the parent retained some equity ownership had active parent representation on the board of directors. On the boards of the two majority-controlled spin-offs, the parent controlled three of five seats, and two of five seats. On the boards of the two minority-controlled spin-offs, the parent controlled two of five seats, and one (non-voting) of five seats. The level of parent ownership was larger in the former spin-off than the latter. The parent had no representation on the boards of the firms who licensed technology or did not employ parent technology.

Spin-offs that were incubated within a structured corporate venturing program formed venture advisory boards when they first entered the incubator. These boards transformed into the first boards of directors when the venture was spun-out.

Of the two ventures that were informally incubated, one formed a board of directors at its first VC-financing round. A second venture, which bootstrapped its growth from its own revenues, did not form a formal board of directors until it had been in business for approximately three years.

Of the two external ventures that subsequently negotiated their separation agreements, one formed a board of directors at its VC-backed A-financing round. A second, which bootstrapped its growth from its own revenues, had not yet formed a board of directors at the time of this writing.

These findings are consistent with the finding of Lerner (1995) and Gompers & Lerner (1999a) that VCs play an active role overseeing their investments, and do so in part through the board of directors.

Figure 13 provides a causal map relating two properties of the governance category back to the core variables (see section 4). The map is not complete. It is provided as an example of the causal maps created during the data analysis process to generate and sort the relationships between each category.

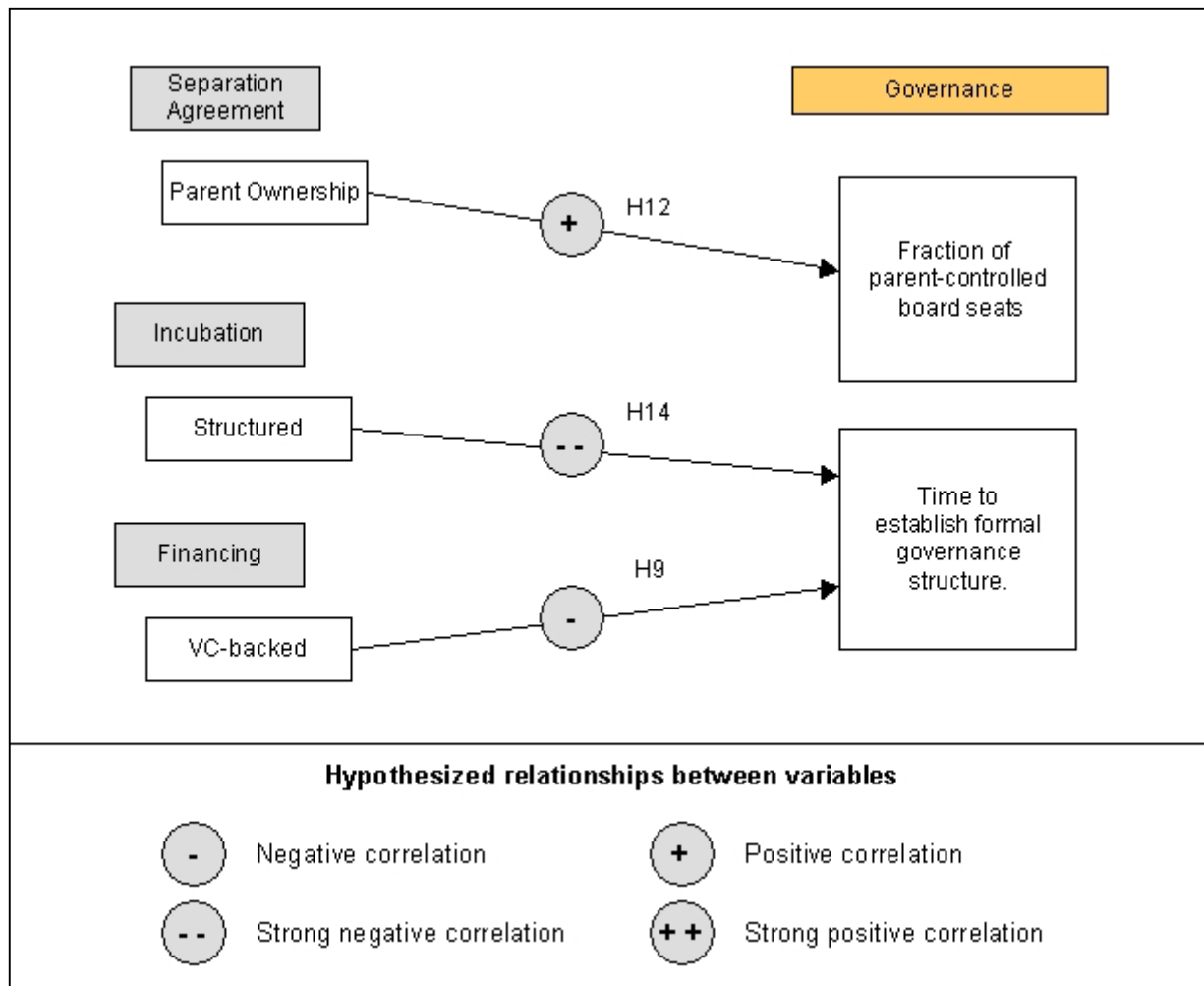

Figure 13: Causal map of selected governance properties

In summary, governance is related to financing (H9, H10), separation agreement (H11, H12, H13) and incubation (H14).

H9: VC-backed new ventures establish formal governance structures at first major financing as a condition of the shareholder agreement demanded by investors.

H10: VC investors take an active role on the boards of directors of their investments.

H11: Separation agreements with parent ownership impact the governance of a new venture;

separation agreements with only licensing do not impact the governance of a new venture.

H12: The fraction of board seats controlled by the parent corporation is related to the level of parent ownership.

H13: For new ventures where the parent has representation on the board of directors, the fraction of board seats controlled by the parent will decline over time.

H14: Ventures in a structured corporate incubator establish formal governance structure early in the incubation process prior to the spin-off event.

Governance impacts the distribution of power in a new venture (H22).

5.5.2 Power

Pfeffer (1992) defines power as the potential to get something done. From the perspective of this study, power is the potential to make and execute on decisions. The power category describes the distribution of power between the stakeholders, and how that distribution of power shifts over time. It was developed by examining the sorts of power issues reported by respondents.

In a venture with multiple stakeholders, the decision-making entrepreneurs share power with others. To a new venture, this includes the formal power derived from positional authority (covered by the governance category in section 5.5.1) and the power derived from control of scarce resources. Power can be bounded by formal restrictions that may prohibit certain courses of action.

The power issues cited by respondents changed over the venture life cycle, and were related to the incubation environment and venture financing.

The power structures of ventures nurtured within a corporate incubator experienced a significant transformation at the spin-off event. The power structures pre-spin-off and post-spin-off are discussed separately below. Start-up spin-offs also experienced a significant transformation at the completion of the separation agreement, although their power structures prior to that transformation were different from those of corporate incubated spin-offs. Ventures that were not incubated did not experience a transformation of the power structure.

Internal ventures within different sorts of corporate incubators faced different sorts of power issues. For the ventures in an informal incubator, there were no established processes for managing and spinning out a venture. One founder explained the decision-making challenges he faced as he readied his business for spin-off,

"We got into a strange mode where we didn't know what our fate was going to be because the decision hadn't been made to let us go. We were in a catch-22. The more successful we were at building functionality into the product and getting more customers, the harder it was becoming for us to get out."

Founders of ventures in informal incubators all acknowledged the support of one or more executive champions (Markham & Griffin, 1998; Schon, 1963). These champions lobbied for support from other executives, helped shelter the venture from its detractors, and were actively involved in securing the support to spin-off the venture. One founder explained the precariousness of his position as follows:

"Many people assumed that we were stable because the parent had deep pockets. In reality, that was wrong. On the whim of an executive, with the stroke of a pen, we could have been gone."

That founder felt more stable once the venture had spun-off with external investment. The climate for decision-making within an informal incubator could vary widely between different ventures with different executive sponsors. Some sponsors adopted a very active "hands-on" management style, while others provided the venture team with near-autonomy within budgetary constraints.

In contrast, a structured incubator had formal processes for decision-making. The internal venture governance structure of the Nortel Networks Business Ventures Program included a *Venture Advisory Board*, the *Business Ventures Group*, and *Venture Boards* for each venture. The *Venture Advisory Board* was the senior decision-making group responsible for venture selection and monitoring, and approval of major investment decisions including the approval to spin-off a venture. The *Business Ventures Group* worked across all ventures, managing the investment process, screening ideas, and coaching project teams through the phases of the process. The group also managed the incubation environment, provided access to services, contributed members to the venture boards, and managed a pool of discretionary seed

money to support promising concepts. Each venture that passed the selection phase became governed by a *Venture Board* that served a role similar to that of a start-up's board of directors. Each Venture Board was responsible for guiding the management team of a particular venture. It was composed of between three and five internal and external individuals to advise the venture team, and would transition into a board of directors for ventures that were successfully spun-out. Some entrepreneurs cited frustration with the pace of some decisions, and the number of individual decision-makers involved in major investment decisions. One founder described his experience presenting to the Venture Advisory Board for seed funding in the early days of the program,

"This was a \$2M fund, but there were sixteen people sitting around the table making investment decisions. I work with Venture Capital firms where three people manage \$100M."

After spinning-out, the power structures at the corporate incubated new ventures changed to more closely resemble those of the ventures that were not incubated.

In addition to their formal role in venture governance, investors exerted a strong influence on VC-financed ventures at each investment round. One venture capital partner explained his role as follows:

"A VC may demand certain changes as a condition of putting money in. Those changes would then become part of the contract, with specified consequences if the changes don't happen in a timely fashion. If we think the management team is weak in a certain area, we may say that as a condition of financing, we expect a VP of Finance to be hired within three months. If we think the team needs an outside CEO, we would say that. All the terms are negotiated. The owners don't have to accept the terms, but if they don't, there may be no deal"

Practitioners reported that the influence of any particular investor was based on many factors. In addition to the formal power provided a position in the governance structure, an investor could also derive power from knowledge, relationships, and the willingness to make future investment. One entrepreneur provided the following specific example:

"If there is a disagreement at a start-up in a financial crisis situation, the shareholders who are able to write cheques will determine strategy."

When the money was running out and the company was dramatically downsized, one particular 4% shareholder ended up calling the shots because they were still writing cheques when some of the larger shareholders would no or could not."

As noted in section 5.5.1, the parent corporation did not invest additional funds after spin-off.

Two ventures (cases E and F) that spun-out with finished products were able to bootstrap their growth from founder investment and their own revenues; these ventures were not VC-financed, and both licensed their technology with no equity ownership by the parent. The resulting governance model and the balance of power in these firms were quite different from those of the VC-financed ventures. One founder explained that for the first three years of operation, the firm had no formal board of directors outside of the founding management team. The team made strategic decisions together without investor scrutiny, with occasional advice from executives at the parent corporation.

The power structures at the start-up spin-off ventures tended to resemble those of the independent ventures with one significant difference. Until the separation agreement was finalized and implemented, the parent corporation retained ownership and control of its intellectual property. Both start-up spin-off cases had been structured such that their product or service utilized that IP. In effect, the parent was a monopolistic supplier of a unique business input that had no available substitute. Thus the parent effectively retained power over the same "go/no go" spin-off decision that it had with its incubated spin-offs – in this case, the decision whether or not to enter into a formal legal agreement that would make the IP available to the new venture at terms that would allow it to succeed.

In summary, the distribution of power changes as a new venture grows and matures (H15). The power of an investor is related to that investor's position in the formal governance structure (H22), influence resulting from contracts (H22), and influence that results from control of resources, including knowledge (H24), relationships, and willingness to make future investment (H16). Willingness to make future investment is a more significant source of power during periods of financial crisis. The distribution of power is related to financing (H17, H18) and incubation (H19).

H17: The distribution of power at VC-backed ventures is different from the distribution of

power at bootstrapped ventures.

H18: VC investors have more leverage to demand changes at funding rounds than at other times.

H19: During the incubation period, power is distributed different for ventures in structured incubators, informal incubators, start-up spin-offs, and ventures that are not incubated.

Power impacts restrictions on the behavior of a new venture (H28).

5.5.3 Restrictions

The restrictions category describes factors that could constrain the set of possible decisions by prohibiting certain actions.

Two sorts of behavioral restrictions were observed. *Formal restrictions* were imposed from outside the venture. They prevented the founding entrepreneurs from making certain decisions, either because those decisions would have been over-ruled by an outside decision-maker, or because those courses of action were prohibited by legal contract. *Cognitive restrictions* were tacit. They prevented the entrepreneurs from making certain decisions that would not have conformed to their own cognitive biases and dominant logic.

Within a corporate incubator, an internal venture was not completely exempt from the processes of the parent corporation. Some restrictions were explicit. For example, while an internal venture was legally part of the corporate parent, its workforce had to be recorded as corporate headcount. Where possible, the founders developed innovative solutions to speed decision-making. A founder of Venture B explained,

"It's always a complicated issue to increase headcount in a big company. We got a big services contract with another firm so that if we wanted someone with obscure directory experience, we could get him a week later. About 30% of our staff was contract. We had an agreement where, once we spun-out, we would transfer those people to us full-time."

A founder of Venture C recalled being caught in a fourth quarter hiring freeze at a time when he wanted to grow the business.

"I thought I was immune to that sort of problem once I received my venture financing. Well, apparently, I wasn't. I had the money, but I wasn't allowed to hire. So, I created my own consulting company which would hire the people I needed. We would then bring them in as consultants so they did not appear on the headcount."

Other restrictions were related to executive expectations and approvals. A founder of Venture C explained:

"A lot of the ways that the parent corporation worked were being superimposed on us and it was not appropriate. Their business was very well established and relatively well known and predictable with their bounds. We were doing something that had never been done before in a space that didn't exist.

We didn't always have the answers. These days, many companies stand up in the financial community and say that they're not going to give any guidance over the next quarter. I tried to do that once and I almost got killed. I really didn't know what my revenue was going to be the next quarter, I said so, and I was barbequed. Man, it was ugly".

These findings are consistent with the corporate venturing literature surveyed in section 2.3 that describes the challenges faced by corporate ventures within large corporations.

Founders of internal ventures within a structured incubator reported fewer restrictions than did founders of ventures within informal incubators. This difference appears to be due to the shelter provided to the new venture by the corporate venturing program that managed the incubator. One venture in a structured incubator made an early sale to a competitor of the parent (working through a intermediary reseller). In contrast, one venture in an informal incubator was only permitted to approach potential customers that did not compete with the parent.

All separation agreements included some formal legal restrictions to protect the interests of the parent corporation. Each agreement was unique. Some possible restrictions included claw-back provisions on intellectual property (see section 5.6.1) related to change of control or investment, requirements for reasonable attempts to commercialize, minimum requirements for external financing, preferred supplier terms to parent corporation, and non-compete requirements.

Cognitive restrictions are more subtle than formal restrictions. One majority-controlled spin-off founder explained that he was encouraged by his investors to make whatever decisions were right for the business, including which of the parent's procedures to adopt, and which procedures to change. Nonetheless, it was easiest to explain decisions to stakeholders from the parent corporation in familiar terms framed by the parent's standard operating procedures. Where parent approval was required, obtaining that approval required less effort for courses of

action that were familiar to executives at the parent. Thus, the cognitive biases of experienced corporate managers (surveyed in section 2.1) tended to be subtly reinforced by the parent. Reinforcement of cognitive restrictions seemed to be stronger in ventures where the parent exerted greater power.

In summary, restrictions are related to the separation agreement (H25), incubation (H26, H27) and the distribution of power (H28).

H25: The separation agreement with the parent may include formal contractual restrictions that prohibit certain courses of action.

H26: While in a corporate incubator, a new venture may be explicitly prohibited from certain courses of action, such as conducting business with a competitor.

H27: While in the corporate incubator, incubated ventures may be constrained by the established operating procedures of the parent corporation. These constraints are lower in a structured incubator than in an informal incubator.

H28: Subtle cognitive restrictions on new venture behavior vary with the power of parent corporation.

Restrictions impact the distribution of power (H23), the process of business model discovery (H32), liquidity alternatives (H36), and the availability of capital (H46).

5.5.4 Business Model

The business model category describes the process of business model discovery for a new venture. Business model and the process of business model discovery is described using the framework of Chesbrough & Rosenbloom (2002) surveyed in section 2.7.

One of the founders of Venture F described his firm's search for a business model.

"In parallel with running our business, we are working to develop a new business model that is a total discontinuity with the way things are done today. We're going to change the rules of the game by changing the game itself.

eBay and Dell both did that. Dell's model drove down the total cost of computer ownership at a time when everyone else was competing on system price. eBay's model made money by putting anonymous customers with anonymous suppliers at a time when

everyone thought that you needed to know your customer and deliver what the customer wants.

You can't tell people about a radical business model. You've got to show them. If it's radically different, they won't understand it or believe it."

These remarks are consistent with Chesbrough & Rosenbloom's (2002) findings on the process of business model discovery.

All cases repositioned themselves in the value network relative to the parent corporation. Five cases (cases A, B, D, E, and H) moved upstream, becoming a supplier to the parent. Three of these cases (cases A, E, and H) moved straight up the supply chain, supplying to companies in the same industry sector. Two other cases (cases B and D) moved laterally as well as upstream, supplying also to large companies in other industry sectors. One fully independent case (case G) moved laterally to compete with the parent in its target segment. Two cases (cases C and F) delivered into new value networks that were unrelated to the value networks of the parent.

New ventures commercializing disruptive technologies experienced greater business model churn than ventures commercializing sustaining technologies. Churn is defined here as a change to one or more of the six business model parameters defined by Chesbrough & Rosenbloom (2002). By extension, the challenge of business model discovery for new ventures commercializing sustaining technology would appear to be one of overcoming inertia. The challenge for new ventures commercializing disruptive technology is one of stabilizing the business model discovery process to establish a stable business.

By all founder accounts, venture capital investors did not seek changes to business models that were working. However, they became very involved in the process of business discovery during periods of crisis. New ventures founded during the Internet boom of period two found the external environment transformed in the technology meltdown of period three. Venture capital investors became highly involved in adapting the business model to the new market climate.

The process of business model discovery occurred in parallel with the process of building new venture legitimacy (see section 5.6.5).

In summary, the process of business model discovery is related to technology

characteristics (H29, H30), financing (H31), and restrictions (H32).

H29: The process of business model discovery for disruptive technologies is longer and experiences greater churn than the process of business model discovery for sustaining technologies.

H30: New ventures commercializing disruptive technologies face a different business model challenge than ventures commercializing sustaining technologies. Ventures commercializing sustaining technologies struggle to reshape their business model to discover a winning model that realizes latent opportunity and differentiates from competition. Ventures commercializing disruptive technologies struggle to stabilize on a winning business model.

H31: VC investors take an active role in the process of business model discovery during times of crisis.

H32: Cognitive restrictions may constrain the process of business model discovery.

5.5.5 Liquidity Alternatives

Researchers and practitioners agree that the most lucrative liquidity event for all stakeholders is the initial public offering of stock (Cummings & MacIntosh, 2002). However, more privately held companies are acquired than go public (Nesheim, 2000, p. 267), and more fail than are acquired (Bhide, 2000). This category considers the liquidity alternatives that may or may not be available to a new venture. It does not attempt to evaluate a venture's probability of "success" or "failure" – merely the options available for investors to exit their investment.

The literature shows that the availability of liquidity options is strongly related to the state of the financial markets, a property of the external environment. IPOs are much more lucrative for investors during periods of high valuations. Likewise, acquisitions are more common during periods of high capital spending that are associated with high market valuations. During the Internet boom of period two, IPOs and acquisitions were common (Nesheim, 2000; Stiglitz, 2002). During the technology meltdown of period three, IPOs and acquisitions were very rare (PricewaterhouseCoopers, 2003).

Venture capital research (surveyed by Gompers & Lerner (1999a, 2001a), Callahan & Muegge (2003), and briefly in section 2.5.2) has shown that VC-backed ventures are more likely

to be successful than non-VC-backed ventures by most, if not all, conventional measures of success. The hypothesis that VC-backed ventures are more likely to have IPO as a liquidity alternative is included here for theoretical completeness. The case study data neither supports nor refutes this relationship.

The case study data does suggest that the separation agreement impacts the opportunities that a new venture may have to be acquired by another company. There are two mechanisms that may constrict liquidity options. First, contractual restrictions may effectively prevent the new venture from being acquired by competitors to the parent. Second, certain potential buyers may be less interested in the new venture because of its association with the parent.

For some cases, the alternatives for liquidity were constrained by contractual restrictions of the separation agreement, particularly "IP claw-back" terms that would cause ownership of the intellectual property to revert back to the parent under certain conditions. As discussed in 5.6.1, the value of a venture could be significantly reduced without intellectual property. The separation agreement for case A stipulated a seven-year license on the intellectual property. The license terms protected the interests of the parent corporation and the royalty paid on each sale provided a sense of legitimacy to the venture. At the end of the licensing period, ownership of the IP transferred from the parent to the venture with no restrictions. According to one of the founders,

"Until then, Northern Telecom owned the IP. There were no restrictions on the sale of our product, but they had the call on to whom we'd be allowed to sell the IP, whether we could amalgamate with another company, or whether another company could buy us outright."

Under the terms of the IP license, the parent corporation could effectively block an acquisition by a competitor. Restrictions that would allow the parent to block an acquisition constrain a new venture's options for liquidity by eliminating firms unfriendly to the parent as potential buyers.

Alternately, a potential buyer that competes with the parent corporation may view a possible acquisition less favorably knowing that the parent corporation may accrue some advantage from the sale. Although some respondents cited this possibility, there were no direct examples of this mechanism in the case study data set. In fact, there are examples of corporate ventures in the Ottawa area (not included in the data set) being acquired by competitors to

parent, such as Nortel Networks' 1998 acquisition of Cambrian Systems, a corporate ventured spin-off of Newbridge Networks (MacDonald, 2000). Newbridge, which was itself acquired by Alcatel in 2000, was a network equipment provider that competed with Nortel in some markets. Such examples, however, do not invalidate the hypothesis. They may well be theoretical replications (Yin, 1989) where the upside value to the buyer of acquiring the venture was greater than the downside of providing benefit to a competitor. Thus, this possible relationship is included in the theory for further testing.

In summary, liquidity alternatives are related to external environment (H33), financing (H34), separation agreement (H35), and restrictions (H36).

H33: A new venture has greater alternatives for liquidity during periods of strong financial markets and high market valuations, thus liquidity alternatives during period two are greater than those of period one, which are greater than those of period three.

H34: VC-backed ventures have greater alternatives for liquidity than bootstrapped ventures.

H35: A competitor to the parent corporation may be less likely to pursue the acquisition of new ventures if the parent corporation would accrue benefit from the sale.

H36: Contractual restrictions, particularly regarding disposal of intellectual property, negatively impact a venture's alternatives for liquidity.

Liquidity alternatives impact the availability of investment capital (H47).

5.5.6 Founder Motivations

The founder motivations category describes the incentives of founder to make a new venture "succeed" and the definition of that success. Three sorts of incentives were discovered – the consequences of failure, the financial rewards of a positive liquidity event, and fulfillment of personal goals.

Some interview respondents believed that corporate ventures offered both lower risk and lower financial rewards for the founders and the staff. This view is supported by remarks in the management literature and popular business press. Consider, for example, the following published remarks, the first from the March 2000 issue of *Fast Company Magazine* and the second from a working research paper:

"All things being equal, the entrepreneurs who launches a successful VC-backed business will almost always come out ahead of the intrapreneur who builds a startup from within a larger company." (Liefer, 2000)

"Should the [internal venture] project not be successful, team members probably will find other tasks within the corporation, provided that they have not been guilty of gross incompetency or malfeasance. The pecuniary rewards for success are modest, so too can be the consequences of failure." (Sahlman, 1992)

Some new venture founders contributed significant personal funds to their venture. Founders of the three internally incubated spin-off ventures that received early VC-financing did not contribute significant personal funds. With respect to exposing their personal savings to risk, founders who did not invest personal funds faced lower consequences of failure.

According to Nesheim (2000), the basis for founder wealth creation is equity at liquidity – the leftovers after all investors have been compensated fully (p. 126). All other compensation plays a small role relative to the potential value of stock options (p. 133). From a wealth creation perspective, the primary goal is IPO, with acquisition providing a secondary and less profitable opportunity for liquidity.

Details of founder compensation are publicly available for only two of the eight case study firms – one through SEC filings, and the other through reports filed with SEDAR. Both firms are corporate ventured technology spin-offs with parent ownership. This publicly available information was compared against the remarks of venture capital respondents and published benchmark data, summarized below.

According to one venture capital partner, his firm typically structured venture financing so that three funding rounds results in founder ownership of approximately two percent per founder (assuming five founders), with founder CEOs retaining as much as five percent ownership. Each investment was unique, and financing terms could vary widely.

Nesheim's (2000) ownership and compensation survey showed that wealth creation for founders and CEOs varied widely. Founder wealth and CEO wealth were surveyed separately because many new ventures recruited an outside CEO that was not an original founder. Wealth rose during boom periods when valuations of stock were higher. Ownership at IPO was higher if the founder or CEO invested personal funds early. Prior to the Internet, CEOs seldom owned

more than 3% of the start-up at IPO. However, by 2000, it was not uncommon to see founder CEOs own 10% to 20% of their start-ups. Founders other than CEOs rarely owned more than 4% at IPO, although the survey did detect some exceptions. In general, founders received much higher payouts than managers who joined later.

The two cases in this study for which ownership data was available had CEO ownership between 2% and 3%, and average founder ownership between 1% and 1.3%. These ownership levels are lower than both Nesheim's survey results and the venture capital targets quoted above. This result is reported here as an interesting insight replicated between two cases rather than a robust causal relationship.

When asked about their motivations for founding a new venture, all founders cited multiple factors. Many of these incentives were similar to those reported in past studies of entrepreneurship (Cooper, 1996; Stanworth et al., 1989; Roberts, 1991; Bhide, 2000), including a desire for independence, pursuit of new challenges, and frustration with corporate culture. More than half of the founders said that they wanted to apply the business and technical learnings acquired at previous employment to their own company. Some believed deeply in commercializing a technology that they believed would not succeed within the parent. According to one founder:

"We realized that we had to escape to succeed. Within a large corporation, we faced 'Death by a Thousand Cuts.' There was no single big problem. It was a thousand little things. Annual budgets that made it hard to get money. Standards that were very particular. Competition with core businesses for legal services. Naturally, a three hundred million dollar switching contract would get priority over our one million dollar [non-core] deal, but for our fast-moving business, delay was death."

Some form of corporate restructuring was a factor in the formation of six cases – four cases were related to projects that were going to be canceled, and two cases were related to canceled projects and layoffs. All period three cases were associated with corporate restructuring.

As noted in section 5.5.5, lucrative liquidity events such as IPO and acquisition are more widely available during periods of strong financial markets. By the same reasoning, founders had greater personal incentives to make decisions favorable to IPO and acquisition during strong markets.

In summary, founder motivations are related to the external environment (H37), financing (H38), incubation (H38), and separation agreement (H39). The hypothesis regarding separation agreement is only weakly supported by case study data.

H37: During periods of strong financial markets, a founder has financial incentives to grow the new venture towards IPO.

H38: The exception is with regards to founder risk. Founders of new ventures that were both internally incubated and VC-financed were not required to invest their own personal funds, and thus faced lower consequences of failure.

H39: Founder ownership is lower for corporate ventured spin-offs than independent new ventures.

5.6 Resource Environment

The relationship between the core variables and the elements of the decision environment is shown in Figure 14 below. Each arrow represents one or more testable hypotheses that are developed in the following subsections and compiled in section 5.7. The relationships between core variables, and between elements of the decision environment and resource environment, are not shown in the figure.

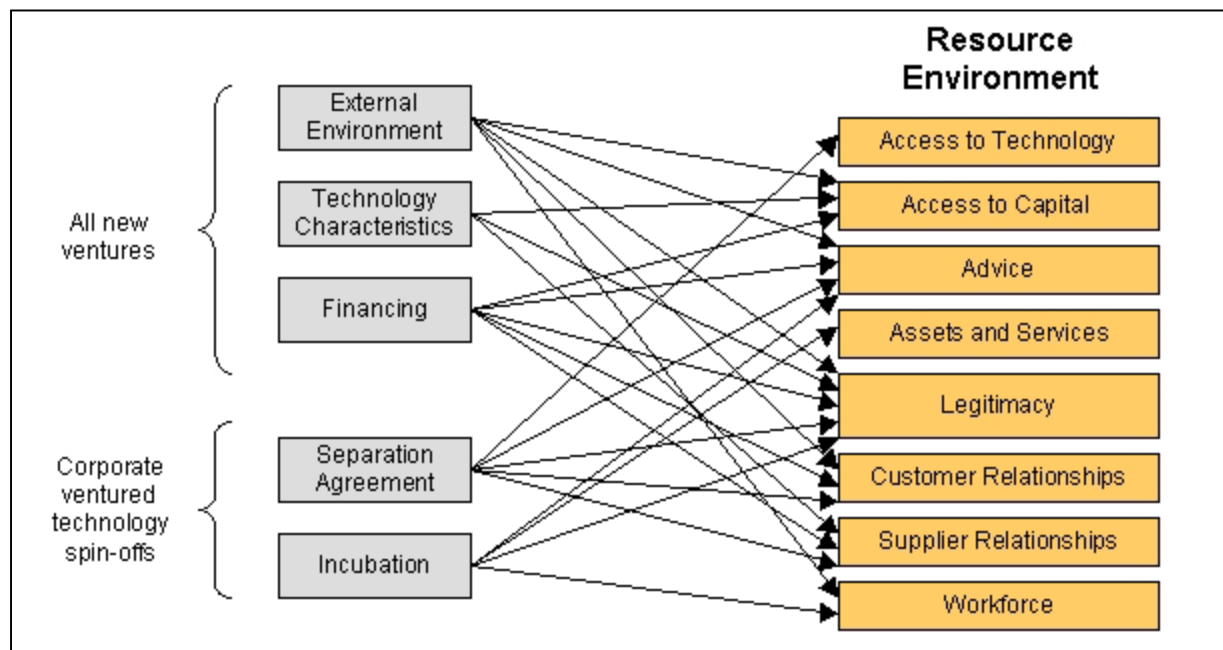

Figure 14: Factors influencing the resource environment

5.6.1 Access to Technology

Corporate ventured technology spin-offs gain access to the parent's intellectual property through the separation agreement, but often with contractual restrictions that may make the firm more difficult to finance. Relevant forms of intellectual property include patents, trade secrets, and product designs.

One entrepreneur explained that patents are an odd asset for a new venture. On one hand, they provide a small company with very little real legal protection. Defending a patent through litigation is very expensive, and few investors would be prepared to fund an extended legal battle against a well-financed corporation. On the other hand, a patent portfolio could be a very attractive asset to a corporation interested in acquiring the small company. Nonetheless, venture capital investors appear to favor firms that own their own patents free of any restrictions or complications.

Another entrepreneur explained his experience with the process of negotiating the transfer of intellectual property ownership:

"Negotiating the transfer of intellectual property was the single most sticky issue of the spin-off. It sounds simple – the parent exchanges ownership of IP for ownership in a new company that could be worth a lot of money at IPO. But the details were time-consuming."

For the new ventures in this study, the negotiation process required between four and twelve months to complete. One particular separation agreement filled six three-inch binders. In most cases, interested venture capital investors also participated the negotiations, and respondents agreed that VC involvement hastened the process.

Executives at the parent corporation were cautious regarding the transfer of intellectual property ownership. As one executive explained, it was possible that a technology could be of value in the future for application that was not yet known. However, transfer of IP ownership was often demanded by outside investors as a condition for investment.

The parent corporation belonged to a competitive cross-licensing patent pool that sometimes complicated the matter of patent ownership transfer. Such pools are common in the semiconductor industry (Grindley & Teece, 1997) and other highly competitive technology

industries where the complexity of overlapping sets of patent rights can delay and introduce new transaction costs to the development and introduction of new products. A cross-license is an agreement between companies that grants each the right to practice the other's patents (Shapiro, 2001). Participants in the patent pool ensure that no other participant in the pool can "hold up" a new product by declaring patent infringement, and reduces the "complements" problem that may otherwise require a firm to secure expensive access to possibly single-sourced patent licenses. Once a patent enters the patent pool, it is not easily extracted.

Through a complex legal arrangement, case C gained ownership of the patent it sought to commercialize, and licensed the patent back to both the parent and to the cross-licensing patent pool. Some potential venture capital investors were unhappy with this arrangement. A founder explains,

"My rebuttal to their concern was that it's not just about our two patents that other firms can access. What about the other patents in pool that we can have access to? This is not a problem – it's a benefit. It took a long while to convince them of that."

Venture capital investors favor firms that have unrestricted ownership of their intellectual property. Nonetheless, the venture did receive VC financing.

Some separation agreements included contractual restrictions that could allow the parent to "claw back" ownership of the intellectual property if certain clauses were violated. Some possible restrictions included reasonable attempts to commercialize the technology, failure to secure financing, and acquisition by specific competitors. Restrictions and their impact on the new venture are described extensively in section 5.5.3.

In summary, technology access is related to the separation agreement (H40, H41).

H40: The separation agreement provides the corporate ventured technology spin-off with ownership of, or access to, intellectual property controlled by the parent.

H41: New ventures with parent ownership were transferred ownership of their intellectual property. New ventures with licensing agreements gained access to intellectual property owned by the parent.

Venture capital investors favor ventures that own their own intellectual property with no

restrictions. There may be contractual restrictions on the IP of a spin-off that could impact the venture's access to capital (H46) or liquidity alternatives (H36).

5.6.2 Access to Capital

The capital category includes a new venture's demand for, and supply of, capital as a resource to grow the new venture. It is closely related to, but distinct from, the financing category (section 5.4.3), which describes whether or not the new venture is backed by venture capital investors.

All VC-backed cases had access to higher levels of capital than all non-VC-backed cases.

The supply of venture capital investment and the willingness of VCs to invest are strongly dependent on the state of the equity markets and other market forces. One entrepreneur described the investment climate faced by group three ventures as follows:

"One of our VCs told us that in the quarter we were put forward, they pre-qualified around 42 business proposals, put seven of them in front of their partners, and invested in one – that was us. Two or three years ago, one in ten would go through. Now, it's one in forty.

VCs are still pushing hard, but in a different way. There are very few deals, most are follow-on rather than new investments, and most are followed by layoffs. VCs are saying that we're going to give you follow-on money but cut back. Tighten your belts and make the money last."

Ventures in period two had access to higher levels of capital and at terms more favorable to the entrepreneur than did period one ventures. Ventures in period three had access to lower levels of capital at terms less favorable to the entrepreneur than did period one ventures.

All new ventures that sought additional financing after spin-off did so by competing for venture capital and angel investment (see section 2.5.2). This study found no evidence that VCs or angel investors provide different treatment to spin-offs. Investors and practitioners all agreed that each potential investment was viewed objectively, evaluated with respect to a fund's investment objectives, and subjected to the same due diligence process. Some characteristics of a spin-off could make it less attractive to an investor. However, that those characteristics are not specifically related to the properties of the separation agreement.

A VC investor explained his perspective on risk:

"For an investor, anything that increases risk is bad. When we put our money in, we also have to have a view to getting our money out. Restrictions on what we can do with that company and who we can sell it to increase our risk and make the investment less appealing."

Thus, contractual restrictions (5.5.3) and constraints on liquidity options (section 5.5.5) could make it more difficult and expensive for a venture to raise capital.

The demand for capital was highly dependent on the resource-intensity of the technology to be commercialized. Ventures commercializing highly resource-intensive technologies required higher capital investment than ventures commercializing medium resource-intensive technologies, with in required higher capital investment than ventures commercializing low resource-intensive technologies. There are two mechanisms that relate demand for capital to resource intensity. First, all costs are higher. A new ASIC may require millions of dollars in non-refundable engineering charges (NRE), compared to a new software-based Internet service that leases its physical assets without any fixed up-front costs. Second, the development interval is longer, so the resource-intensive project takes longer to develop.

In summary, access to capital is related to the external environment (H42), technology characteristics (H43), financing (H44), restrictions (H46), and liquidity (H47). Access to capital is not related to the separation agreement (H45).

H42: The availability of capital during period two was greater than the availability of capital during period one, which was greater than the availability of capital during period three.

H43: Demand for capital is related to resource intensity.

H44: VC-backed new ventures tend to be better financed than bootstrapped new ventures.

H45: Investors do not systematically treat corporate ventured technology spin-offs either more favorably or less favorably than independent new ventures.

H46: Contractual restrictions negatively impact a venture's access to risk capital.

H47: Constraints of a new venture's alternatives for liquidity negatively impact a venture's access to risk capital.

5.6.3 Advice

The advice category describes the guidance provided to the decision-making entrepreneurs, including the sources, quantity, quality, and the specific nature of that advice.

Founders agreed that all investors advised the new venture through formal and informal channels. Formal channels included the board of directors and the governance model (5.5.1). Informal channels included such things as meetings and telephone conversations. For the ventures in this study, those investors were primarily risk capital investors (including VCs, angel investors, and seed investors) and stakeholders from the parent corporation. Incubated ventures had greater access to informal advice from the parent during the incubation period.

One founder explained that his venture capital investors were helpful and supportive, and very active in areas where they could add value, including helping to write the first marketing brochures. In his experience, VCs provided their opinion on issues and shared their experience on what had worked in other companies. However, as long as decisions were grounded in real feedback from partners and customers, the VCs always deferred. Another founder explained that his VCs helped recruit sales and marketing staff, and advised on the market timing of press releases and product announcements.

The nature of the advice from investors was strongly related to external environment. One investor explained his perspective on the differences between VC guidance during the technology boom of period two and the technology meltdown of period three.

"The old model was, find a good concept, throw a ton of money at it, and make sure that you're first to market. A VC investor today wants to see a clear path to profitability. They want to see a focus on a revenue stream that is believable and repeatable and not just a one-shot flash in the pan."

During the Internet boom of period two, venture capital investors encouraged their firms to grow quickly and push towards IPO. A founder of case C recalls:

"We were under a lot of pressure to grow fast and do high-profile public relations. One of our competitors had already gone public on much less revenue, and our California-based VC wanted to see us follow suit quickly. My PR expenses and airline bills were astronomical. At the same time, we were trying to run a business."

The bubble was pushing our burn-rate. Once you get on that ride, you can't get off. You can't ask if it makes sense for company that's only a year old to go public. Those conversations go nowhere."

Venture D was also spun-out during period two, but after the dot-com collapse of April 2000 and prior to the technology meltdown. Its venture capital investors had already grown cautious, and advised a more modest growth plan. A founder of Venture D explains:

"We're a small business and we're frugal with our money. We didn't grow any faster than we needed to – in fact, we have never had more than twenty-eight employees. That means we need a laser-like focus on high impact activities. We focus on securing deals and building the business. We don't do much PR with local media. We distribute our product through resellers, so end-customer awareness and expensive marketing campaigns are not a priority."

In the period three technology meltdown that followed the irrational exuberance (Shiller, 2000) of period two, investors advised caution. As described in section 5.6.2, investors in period three often demanded spending controls and layoffs as a condition for financing. They advised their investments to cut back on expenditures, focus on securing revenues, and work towards profitability.

According to founder accounts, the quality of an investor's advice on any particular topic was related to the relevance of that investor's knowledge and experience. This was particularly significant regarding the advice of the corporate parent. Founders of ventures supplying a product or service to the parent corporation reported that the parent's customer feedback was highly valued in shaping product and market decisions. Founders of ventures pursuing markets and business models that differed significantly from those of the parent reported less value from the strategic advice of the parent. By extension, advice from the corporate parent would be expected to be of greater value for new ventures with business models and target markets similar to those of the parent. This finding is consistent with research on complementarity of corporate ventures (Athey & Stern, 1997) and spin-offs (Parhankangas & Arenius, 2003).

In summary, the supply of advice is related to financing (H50), the separation agreement (H51), and incubation (H52). The nature of the advice is related to external environment (H49). The quality of advice from any stakeholder is related to the relevance of their experience and knowledge to the circumstances of the new venture (H48).

H49: During period two, VCs advised aggressive growth. During period three, VCs advised a focus on cost control, revenues, and profitability, sometimes demanding spending controls.

H50: VC investors provide advice to their investments.

H51: Stakeholders from the parent corporation provide advice to their investments.

H52: Incubated ventures have greater access to advice from the parent during the incubation period.

Advice impacts the distribution of power (H24).

5.6.4 Assets and Services

Ventures that emerged from an incubator had access to products and services that were not available to other ventures. One founder explains,

"Most people think that every start-up's worst nightmare is dealing with staffing and funding. Wrong. It's the limited number of hours in a day that can kill you. So you don't want to waste time at office-supply stores."

Ventures that were informally incubated could access the same corporate services that were available to the parent's internal business units. Ventures incubated within a structured corporate venturing program could access services that were streamlined for smaller ventures. The incubator provided infrastructure, legal support, office-space, public relations support, human resources, finance and tax expertise, supply management, corporate communications, corporate standards, assistance with mergers and acquisitions, and access to marketing and sales staff of parent's lines of business. These services are not unique; many are available from privately-funded for profit *networked incubators* (Hansen, Chesbrough, Nohria & Sull, 2000), publicly funded government incubators, experienced *angel investors* (Fenn, Liang & Prowse, 1997), and some high-service venture capital firm specializing in early-stage seed investment. Nonetheless, for the ventures in the structured incubator, these services were explicit.

In summary, assets and services are related to incubation (H53). Ventures in corporate incubators have greater access to assets and services than do ventures that are not incubated. Ventures in structured corporate incubators have greater access to assets and services than ventures in an informal incubator.

5.6.5 Legitimacy

A body of research reviewed earlier (see section 2.6) highlights the legitimacy problems faced by new ventures (Block & MacMillan, 1993, p. 285; Aldrich & Fiol, 1994; Schoonhoven & Eisenhardt, 1996). All agree that endorsements and relationships are required to overcome low legitimacy.

Broadly speaking, a "legitimate" venture fits market expectations for a successful new business – it is in compliance with the law and accepted practices, it is believed to be of at least reasonable quality, and it is expected to be at least moderately successful. Aldrich & Fiol (1994) define two specific operationalized forms of legitimacy, that of *cognitive legitimacy* (how "taken for granted" a new form is, measured by the level of common knowledge) and *sociopolitical legitimacy* (the extent to which a new form conforms to recognized principles or accepted rules or standards, and the extent to which key stakeholders accept a venture as appropriate or right given existing norms). Collectively, this study refers to cognitive and sociopolitical legitimacy together as *external legitimacy* – the legitimacy that a new venture has in the marketplace.

All of the ventures in this study benefited to some extent from their common origins at an established parent corporation. This *entrepreneurial prominence* (Burton, Sorensen & Beckman, 2001) (see section 2.6) was a common control across all cases selected for inclusion. It did not favor any particular case over any other.

Ventures that were supported by the parent through corporate venturing activity started life with some endorsements. Each endorsement was perceived by the marketplace as a signal of the parent's confidence that the venture would succeed and not damage its own reputation, thus increasing the sociopolitical legitimacy of the new venture. Endorsements cited by respondents included investment, technology transfer, technology licensing, buying products or services, and providing brand support. Ventures that commercialized technology developed at the parent also gained sociopolitical legitimacy. The parent had a reputation for technical excellence and highly reliable products. Technologies developed there were expected by the marketplace to be of high quality.

Ventures that could leverage the parent's widely recognized brand value also gained cognitive legitimacy. While the venture itself may have been new, the parent's form was already

common knowledge with potential customers, suppliers and partners. The spin-off became familiar by sharing branding with the parent.

The founder of Venture C explains how the parent's name opened many doors with customers,

"I had many conversations like this:

- *Hi. We're [Venture C]. We're a Nortel spin-off company. We would like to come and tell you about our product.*
- *Did you say 'Nortel?'*
- *Yes. It will only take about an hour.*
- *Sure.*

It's like Rolls Royce selling you ice cream. They recognize the name, they're not sure why they're selling that product, but they expect it to be good."

Even after the initial pitch, the connection with an established parent helped land deals.

"I was told several times, 'If you guys weren't Nortel, we wouldn't do this.' Of course we were quite clear that we were a spin-off company, but people seemed to only remember the 'Nortel' part."

The literature suggests other possible methods for a new venture to raise its legitimacy including the endorsements of prominent lead customers, partners, suppliers, investors, and independent board members. Nonetheless, corporate ventured spin-offs are formed with valuable endorsements already in place, and would thus appear to have an advantage in this area.

Venture capital financing provided VC-backed new ventures with a major endorsement that improved legitimacy in the marketplace. Many ventures reported receiving better treatment from customers and suppliers after announcing venture capital financing.

Sustaining technologies that delivered into familiar value networks had more legitimacy than disruptive technologies that delivered into new value networks.

Ventures founded during period one in an informal incubator wrestled with an additional legitimacy problem – the founders' lack of *entrepreneurial legitimacy*. To those outside to parent corporation, the venture appeared more legitimate because the parent endorsed it. Within

the parent corporation, however, the founders initially had little credibility as entrepreneurs. One of the founders of Venture B recalls:

"Very early on, colleagues would look at us and say, 'You guys know how to build telephone switches. What do you know about running your own business?'

We worked hard to prove ourselves and score credibility points."

The founder reported that his credibility improved after the venture signed a major international customer.

Founders of ventures in a structured incubator during period two did not report facing any problems with entrepreneurial legitimacy. The causal factor appears to be the change in external environment, specifically the regional conditions and the attitudes at the parent corporation. During period one, corporate venturing was rare at the parent company. Nortel was primarily a supplier of telecommunications voice products to established telephony carriers. With the rise of the Internet and the subsequent dot-com boom, starting up new technology ventures became normalized. The growing number of success stories and the potential for wealth creation encouraged entrepreneurially minded employees. With the establishment of an internal corporate venturing program in late 1996, some executives at the parent corporation formally sanctioned internal ventures and spin-offs as legitimate goals for premium employees. Ventures that entered the corporate venturing incubator became endorsed by management. With Nortel's right-angle turn of December 1997, a more entrepreneurial climate became corporate policy across the company. It was no longer unusual to want to spin-off a business, and no period two venture founders cited entrepreneurial legitimacy as an issue.

Likewise, period three founders reported no issues with entrepreneurial legitimacy. These ventures were all founded in an era of cutbacks and cost reduction, at the parent and throughout the technology sector. Many former employees of established parent corporations were founding their own businesses with hopes of commercializing cancelled projects or leveraging the learnings from their past employment. As with period two ventures, entrepreneurship was expected behavior.

The process of building legitimacy occurred in parallel with the process of business model discovery (section 5.5.4).

In summary, external legitimacy is acquired by securing endorsements, including investor endorsements (financing), parent endorsements (commercializing technology from the parent, technology transfer, technology licensing, customer relationships, and branding), and market endorsements (high-profile customers, suppliers, partners, and external directors) (H54). External legitimacy is related to technology characteristics (H56), financing (H57), and separation agreement (H58).

H56: Sustaining technologies have greater external legitimacy than disruptive technologies.

H57: VC-backing increases the legitimacy of a new venture.

H58: New ventures that license technology have more parent endorsements than independent ventures, and thus greater external legitimacy. Ventures with higher parent ownership tend to have more parent endorsements than ventures with lower parent ownership, and thus greater legitimacy.

Entrepreneurial legitimacy is related to external environment and incubation (H55).

H55: Founders of corporate ventures during period one expended energy building entrepreneurial legitimacy within the parent corporation.

External legitimacy improves a venture's access to customers (H49) and suppliers (H54).

5.6.6 Customer Relationships

The customer relationships category describes a new venture's access to customers.

According to the practitioners interviewed in this study, potential customers favored legitimate suppliers that they believed would reliably deliver quality products. A founder of case B explained that customers liked the Nortel pedigree of his company.

"They weren't about to trust their critical infrastructure to a basement start-up."

The two fully independent ventures both devoted substantial effort to building legitimacy through technical achievement, signing high-profile lead customers, and developing networks of partners. The spin-offs that commercialized technology from the parent corporation also worked to build legitimacy, but they seemed to start at an advantage.

Some spin-offs were created to supply a product or service to the parent corporation.

These ventures started life with a high-profile lead customer while other ventures needed to build that first relationship. Some founders cited examples of accommodations by the parent that would not have been offered to other suppliers. In exchange for early terms that favored the new venture, the parent often demanded the inclusion of contractual guarantees of favorable future terms in the legal separation agreement.

VC-backed ventures had better access to customers than non-VC-backed ventures. It was already shown in section 5.6.5 that VC-backing improved legitimacy. Based on the previous arguments in this section, that improved legitimacy would be expected to improve access to customers. However, VC-backing can also directly improve access to customers. In some instances, VC partners assisted with contacting customers and securing the opportunity to make a first customer presentation.

Access to customers was also related to the separation agreement. Majority-controlled spin-offs, where parent ownership was greater than fifty percent, reported receiving assistance from the sales teams at the parent corporation. In both cases, the new venture had commercialized a product or service that differed significantly from the parent's core business, thus the decision-makers at the customer firm were different. Nonetheless, support from the parent was occasionally helpful for making introductions and receiving the invitation to make an initial presentation. Ventures that were not majority-controlled by the parent did not report receiving such assistance.

A spin-off's relationship to the parent corporation could also limit access to some customers. For example, two competitors of the parent corporation eventually became major accounts of one venture. Those competitors initially had reservations about conducting business with the spin-off. The venture invested a year of sales and marketing effort to deal with those issues before securing the first sale. One of those customers later became the largest account for a time. According to one VC investor, the presence of parent-nominated directors on the board of directors would be particularly discouraging to a competitor that sought to protect trade secrets. One venture established guidelines that a board member nominated by the parent would not be privy to customer information regarding potential competitors. Nonetheless, the relationship could discourage some customers.

Lastly, spending patterns of some customers were strongly related to the external environment. If a customer is struggling to control spending, in addition to purchasing less from its existing suppliers, it may be less willing to consider new suppliers. Thus, period two ventures tended to have better access to customer than period one ventures, which had better access to customers than period three ventures.

In summary, access to customers is related to the external environment (H59), financing (H60), the separation agreement (H61, H62), and legitimacy (H63).

H59: Period two ventures tend to have better access to customer than period one ventures, which have better access to customers than period three ventures. VC-backed ventures have better access to customers than non-VC-backed ventures.

H60: VC-backed ventures have better access to customers.

H61: Majority-controlled ventures can leverage the parent's sales organization. Through the support of the parent's sales organization, majority-controlled ventures have greater access to customers in the parent's value network. This relationship is more valuable to new ventures that sell a product or service into the parent's value network.

H62: A spin-off's relationship to the parent corporation can limit access to some customers. A venture with a separation agreement from the parent has reduced access to customers that compete with the parent.

H63: Ventures with greater external legitimacy have greater access to customers.

Factors that improve external legitimacy (H49, H50, H51, H52) improve a new venture's access to customers.

5.6.7 Supplier Relationships

The supplier relationships category includes all aspects of a new venture's relationships with suppliers and partners, including whether or not a particular supplier will sell to a new venture, and the terms of the supply agreement.

Like customers, suppliers and partners were also concerned with the longevity of new ventures. A founder of case G explained,

"Partners aren't going to waste their time and effort working with small start-ups unless there's something real there."

The same legitimacy factors that improved a new venture's access to customers (see section 5.6.6) also improved their access to suppliers and partners.

Particularly for independent new ventures, venture capital financing was an important proof-point. A founder of case H explains,

"Suppliers didn't take us seriously before we had VC money.

At Nortel, if I had been interested in something from a supplier, I would have picked up the phone, called them, and asked for a price. Someone would have called me back right away with the answer. When the other founders and I decided to start a new company, I went in thinking that we would set up all our supplier relationships at the same time as we were raising financing. Then, when the VC deal closed, we would hit the ground running with the supply chain ready to go.

It didn't work out that way at all. It turned out that we had to pitch to vendors the same way we pitched to VCs. We had to convince them to sell to us. There was lots of travel – they wouldn't come here to visit us. At the meetings, there were always questions about funding.

After our VC funding closed, everything changed. The phone started to ring with unsolicited offers from vendors. We repitched to all our suppliers and partners and got better terms."

Access to suppliers was also related to the separation agreement. New ventures that were majority-controlled by the parent corporation were able to leverage the parent's contractual supply agreements for preferred pricing and delivery terms. Access to these supply agreements was more useful for ventures that sought to do business with existing suppliers of the parent corporation

Supplier agreements were much more significant for ventures commercializing a resource intensive technology. One venture found that for fabricating a complex ASIC, the difference in upfront engineering costs between preferred supplier terms and standard book price was on the order of millions of dollars.

In summary, access to suppliers is related to financing (H65), the separation agreement (H66), and legitimacy (H67).

H65: VC-backed ventures have better access to suppliers and partners than bootstrapped

ventures.

H66: Majority-controlled ventures can leverage the parent's established supply relationships for premium service, pricing, and terms. This is more significant for ventures that seek to acquire inputs from suppliers of the parent corporation.

H67: Ventures with greater external legitimacy have greater access to suppliers.

Improving access to suppliers is more significant for ventures commercializing resource-intensive technologies (H64). Factors that improve external legitimacy (H49, H50, H51, H52) improve a new venture's access to customers.

5.6.8 Workforce

The workforce category examines differences in the composition, talents, and expectations of the employees.

Although not triangulated with other data sources, interview responses suggest that the workforce of large corporation differs from the workforce of a small start-up. Two workforce *profiles* emerged. The corporate profile favored the perceived attributes of a large corporation, including job security, benefits, and stability. The start-up profile favored the perceived attributes of a new venture, including the potential for high returns if the venture succeeds, the feeling of empowerment and self-worth by making a visible contribution to a small organization, and a tolerance for risk. The profile of a spin-off workforce may fall between the corporate and start-up profiles, varying with spin-off's relationship to parent firm.

A corporate ventured spin-off, particularly one that is majority controlled, may attract a workforce that is more similar to that of the parent corporation. This could be an advantage for a new venture that requires scarce skills and talents that are available within the parent. According to one founder of case B,

"Our spin-out offered employees a more appealing transition opportunity than quitting to join a start-up. For instance, our employee benefits package looked very similar to what they were used to. It was lower risk. If an employee later wanted to go back, we had an understanding that their service would be bridged. Would [the parent] do that for someone who came back from a start-up? Perhaps. But with us, it was explicit."

In contrast, one independent new venture demanded up-front employee investment and initially

paid its staff half in company stock. This could be a deterrent to risk-averse workers.

New ventures founded during period 3 all reported access to a large supply of talent. Following the dot-com collapse and the technology industry meltdown, start-ups and spin-offs alike were able to hire highly talented staff that had been downsized by their former corporate employers.

In summary, the workforce is related to the external environment (H68) and the separation agreement (H69).

H68: Ventures founded during period three had access to a larger supply of talent than ventures founded during periods one or two.

H69: New ventures that are more closely related to the parent (higher parent ownership, licensing) have a workforce profile that more closely resembles the workforce profile of the parent. New ventures that are less closely connected to the parent (lower parent ownership, no licensing) have a workforce profile that more closely resembles that of a start-up.

5.7 Solution to the Research Problem

This section presents the solution to the research problem posed in section 1.1. It compiles the complete emergent grounded theory developed in sections 5.3 to 5.6.8 using the terminology of Glaser & Strauss (1967). Section 6 discusses the implications of this model using terminology that may be more familiar to management researchers and practitioners.

Five categories account for most of the observed differences in the decision and resource environments of the new ventures in the data set of this study. Three categories are common to all new technology ventures – the *external environment*, *financing*, and *technology characteristics*. These are included for theoretical completeness. Two core categories address the main focus of this study – the differences in the decision and resource environments between corporate ventured technology spin-offs and other new ventures. Those core categories are specific to corporate ventured technology spin-offs – the *separation agreement*, and the *incubator*.

The *external environment* includes environmental factors external to the new venture over which the founding entrepreneurs have no control, including market conditions, regional conditions, and conditions at the parent corporation. It is a typology of three time periods. *Period one* is the long interval of sustained economic growth in the early and mid-1990s, spanning approximately the years between 1992 and 1997. *Period two* is the technology boom of the late 1990s, spanning approximately 1998 to 2000. During period two, the parent corporation sponsored a corporate venturing program and increased its level of participation in forming spin-offs. *Period three* is the technology industry meltdown that followed the dot-com collapse, spanning approximately 2001 to 2002.

The *financing* category characterizes the source of capital to fuel the growth of the new venture. It is a binary typology. *VC-backed* ventures are financed by venture capital or other risk capital investors. *Bootstrapped* ventures are financed by founder investment, private investment, and re-investment of revenues.

The *technology characteristics* category describes the innovation that the new venture seeks to commercialize. It has two properties. *Resource intensity* describes the requirement for resources such as capital, knowledge, and development interval. It is a relative scale ranging

from low to high. *Innovation type* is a binary typology. *Sustaining technologies* foster improved mainstream product performance and deliver into existing value networks. *Disruptive technologies* bring to market a different value proposition and deliver into non-mainstream value networks.

The *separation agreement* describes the legal relationship between the new venture and the parent corporation, and the arrangements by which the new venture acquires or gains access to intellectual property of the parent. There are two possible arrangements. In the first arrangement, the parent transfers ownership of the intellectual property in exchange for partial ownership of the new venture. In the second arrangement, the parent licenses access to the intellectual property but retains ownership, possibly in exchange for royalties to be paid to the parent. To describe these arrangements, the separation agreement has two properties. *Parent ownership* is a scale from 0% to 100%. New ventures with parent ownership greater than 50% are termed *majority-controlled* spin-offs. New ventures with parent ownership greater than zero but less than 50% are termed *minority-controlled* spin-offs. *Licensing* is a Boolean variable – a separation agreement either has licensing or not. *Corporate ventured technology spin-offs* have either ownership greater than 0%, a licensing agreement, or both. *Independent new ventures* have 0% ownership and no licensing.

Incubation describes the climate in which an embryonic new venture is nurtured. It is a typology of four types. *Structured* incubators are managed within a corporate venturing program at the parent corporation. They have processes and a governance framework. *Informal* incubators are semi-autonomous business units within the parent corporation or wholly owned subsidiaries of the parent. They are not organized together as a corporate venturing program, and have no formal corporate venturing processes. Both structured and informal incubators are managed by the parent corporation and are collectively called *corporate incubators*. A new venture may reside in a corporate incubator between the formation event and the spin-off event. *Start-up spin-offs* are formed outside of the parent corporation without a formal separation agreement in place. They are not incubated in a corporate incubator. They later enter into a formal separation agreement with the parent for access to IP. Independent new ventures are *not incubated*.

From the purpose of characterizing the decision and resource environment, a new venture can be operationalized according to the data structure in Figure 15.

- **external environment**, typology (period 1; period 2; period 3)
- **technology characteristics**, matrix of two properties
 - **resource intensity**, range (low to high)
 - **innovation type**, typology (sustaining; disruptive)
- **financing**, typology (VC-backed; bootstrapped)
- **separation agreement**, matrix of two properties
 - **parent ownership**, range (0% to 100%)
 - **licensing**, Boolean (yes; no)
- **incubation**, typology (none; structured; informal; start-up spin-off)

Figure 15: Operational data structure characterizing a new venture

The *decision environment* is the totality of circumstances and conditions that surround the decision-making entrepreneur to determine the scope of possible decisions, the set of all possible courses of action, and various factors that could influence the outcome of a decision. The elements of the decision environment are *governance*, *power*, *restrictions*, *business model*, *liquidity alternatives*, and *founder motivations*. *Governance* is the distribution of formal power within a new venture and the changes within that formal structure over time. *Power* is the potential to get something done. The power category describes how power is distributed within a new venture, and how that power distribution changes over time. *Restrictions* describe the formal and cognitive constraints on decision-making. The *business model* describes the process of business model discovery at the new venture. *Liquidity alternatives* describe the available options for liquidity events, including the companies that may be interested in acquiring the venture. *Founder motivations* include the incentives of a founder to make a new venture succeed, and the definition of that success.

The *resource environment* is the set of all possible resources that a decision-making entrepreneur can deploy to help make and execute on their decisions. The elements of the resource environment are *access to technology*, *access to capital*, *advice*, *assets and services*, *legitimacy*, *customer relationships*, *supplier relationships*, and *workforce*. *Access to technology*

describes a new venture's access to patents and trade secrets. *Access to capital* is the supply of and demand for money to drive the growth of the new venture. *Advice* is the quantity and quality of guidance provided to the founding entrepreneurs. *Assets and services* describes various corporate services, including infrastructure, legal support, office space, and human resources management. *Legitimacy* describes how well a venture fits with market and corporate expectations of a successful new business. *Customer relationships* describe a new venture's access to buyers who could potentially provide a source of revenue. *Supplier relationships* describe a new venture's access to business partners, and to vendors who provide the inputs to the business. *Workforce* describes the composition, talents, and expectations of employees.

Table 4 shows the emergent relationships between categories, and Table 5 compiles these relationships into a list of testable hypotheses.

The categories are highly interconnected. Nonetheless, the model simplifies for comparison of similar new ventures. As an example, to account for differences in the decision and resource environments between two VC-backed new ventures commercializing similar technologies and founded at approximately the same time, only the separation agreement and incubation environment need be considered. The five core categories would collapse down to two.

Table 4: Relationships between categories (cause and effect)

		Effect →			Core		Decision Environment					Resource Environment								
		External Environment	Technology Characteristics	Financing	Separation Agreement	Incubation	Governance	Power	Restrictions	Business Model	Liquidity Alternatives	Motivations	Access to Technology	Access to Capital	Advice	Assets	Legitimacy	Customer Relationships	Supplier Relationships	Workforce
← Cause	External Environment				H4 H5			H15 H16						H48		H54				
		External Environment		H1		H8					H33 H37			H42 H49			H55 H59			H68
		Technology Characteristics		H2						H29 H30				H43			H56		H64	
	Core	Financing			H3 H6 H7		H9 H10	H17 H18		H31 H34 H38				H44 H50			H57 H60 H65			
		Separation Agreement			H3		H11 H12 H13		H25		H35 H39	H40 H41	H45 H51			H58 H61 H62	H66 H69			
	Decision Environment	Incubation					H14 H20 H21	H19 H26 H27			H38			H52 H53 H55						
		Governance						H22												
		Power							H28											
		Restrictions						H23		H32 H36			H46							
		Business Model																		
Liquidity Alternatives												H47								
Resource Environment	Motivations																			
	Access to Technology																			
	Access to capital																			
	Advice						H24													
	Assets																			
	Legitimacy															H63 H67				
	Customer Relationships																			
Supplier Relationships																				
Workforce																				

Table 5: Emergent hypotheses

#	Relationship	Categories	Ref
H1	The availability of venture capital financing for new ventures is related to the external environment. The availability of VC financing during period two was greater than the availability of VC financing during period one, which was greater than the availability of VC financing during period three.	External Environment Financing	5.4.3
H2	Financing is related to technology characteristics. New ventures commercializing resource-intensive technologies require high levels of financing. Such high levels of financing are difficult to bootstrap.	Technology Characteristics Financing	5.4.3
H3	Financing and separation agreement are correlated. Spin-off events are likely to coincide with the announcement of venture capital financing.	Separation Agreement Financing	5.4.3
H4	The properties of the separation agreement are time-dependent. Parent ownership declines over time as the parent's investment becomes diluted, unless the parent provides follow-on investment.	Separation Agreement	5.4.4
H5	Negotiating the separation agreement requires a sizable commitment of time and effort by both the founding entrepreneurs and the parent corporation.	Separation Agreement	5.4.4
H6	The separation agreement is related to financing. A parent corporation may be more willing to enter into a separation agreement involving parental ownership and the transfer of IP ownership with new ventures that have secured venture capital financing. For some internal ventures, the spin-off event may be contingent on securing VC financing.	Financing Separation Agreement	5.4.4
H7	The separation agreement is related to financing. VC investors actively participate in the negotiation of the separation agreement between the founding entrepreneurs and the parent corporation. Financing may be contingent on a favorable separation agreement.	Financing Separation Agreement	5.4.4
H8	Incubation is related to the external environment. Structured incubation is only available within a corporate venturing program. For this data set, the parent established a corporate venturing program only during period 2.	External Environment Incubation	5.4.5
H9	Governance is related to financing. VC-backed new ventures establish formal governance structures at first major financing, as a condition of the shareholder agreement with investors.	Financing Governance	5.5.1
H10	Governance is related to financing. VC investors take an active role on the boards of directors of their investments.	Financing Governance	5.5.1
H11	Governance is related to the separation agreement. Separation agreements with parent ownership impact the governance of a new venture; separation agreements with only licensing do not impact the governance of a new venture.	Separation Agreement Governance	5.5.1
H12	Governance is related to the separation agreement. The fraction of board seats controlled by the parent corporation is related to the level of parent ownership (as would be expected for any investor).	Separation Agreement Governance	5.5.1
H13	Governance is related to the separation agreement. For new ventures where the parent has representation on the board of directions, the fraction of board seats controlled by the parent will decline over time.	Separation Agreement Governance	5.5.1
H14	Governance is related to incubation. Ventures in a structured corporate incubator establish formal governance structures early in the incubation process (prior to the spin-off event).	Incubation Governance	5.5.1
H15	Power is time-dependent. The distribution of power changes as the new venture grows and matures.	Power	5.5.2

#	Relationship	Categories	Ref
H16	The power of an investor is related to the investor's willingness to make future investment. This source of power is more significant during periods of financial crisis.	Power	5.5.2
H17	Power is related to financing. The distribution of power at VC-backed ventures is different from the distribution of power at bootstrapped ventures.	Financing Power	5.5.2
H18	Power is related to financing. VC investors have more leverage to demand changes at funding rounds than at other times.	Financing Power	5.5.2
H19	Power is related to incubation. During the incubation period, power is distributed differently for ventures in structured incubators, informal incubators, start-up spin-offs, and ventures that are not incubated.	Incubation Power	5.5.2
H20	The variance in power is related to incubation. During the incubation period, the level of executive involvement can vary widely between different ventures. The variance in executive involvement is greater for ventures in informal incubators than for ventures in structured incubators.	Incubation Power	5.5.2
H21	Power is related to incubation. Internal ventures in an informal incubator are dependent on the support of an executive champion.	Incubation Power	5.5.2
H22	Power is related to governance. The power of an investor is related to the investor's formal positional authority in the governance structure.	Governance Power	5.5.2
H23	Power is related to restrictions. The power of an investor is related to influence derived from contractual restrictions.	Restrictions Power	5.5.2
H24	Power is related to advice. The power of an investor is related to the quality of that investor's advice and the perceived potential of that advice to benefit the new venture.	Advice Power	5.5.2
H25	Restrictions are related to the separation agreement. The separation agreement with the parent may include formal contractual restrictions that prohibit certain courses of action.	Separation Agreement Restrictions	5.5.3
H26	Restrictions are related to incubation. While in a corporate incubator, a new venture may be explicitly prohibited from certain courses of action, such as conducting business with a competitor.	Incubation Restrictions	5.5.3
H27	Restrictions are related to incubation. While in the corporate incubator, incubated ventures may be constrained by the established operating procedures of the parent corporation. There are fewer constraints in a structured incubator than in an informal incubator.	Incubation Restrictions	5.5.3
H28	Restrictions are related to power. Subtle cognitive restrictions on new venture behavior vary with the power of the parent corporation.	Power Restrictions	5.5.3
H29	Business model discovery is related to technology characteristics. The process of business model discovery for disruptive technologies is longer and experiences greater churn than the process of business model discovery for sustaining technologies.	Technology Characteristics Business Model	5.5.4
H30	Business model discovery is related to technology characteristics. New ventures commercializing disruptive technologies face a different business model challenge than ventures commercializing sustaining technologies. Ventures commercializing sustaining technologies struggle to reshape their business model to realize latent opportunity and differentiate against competition. Ventures commercializing disruptive technologies struggle to stabilize on a winning business model.	Technology Characteristics Business Model	5.5.4
H31	Business model discovery is related to financing. VC investors take an active role in the process of business model discovery during times of crisis.	Financing Business Model	5.5.4

#	Relationship	Categories	Ref
H32	Business model discovery is related to restrictions. Cognitive restrictions may constrain the process of business model discovery.	Restrictions Business Model	5.5.4
H33	Liquidity alternatives are related to the external environment. A new venture is more likely to achieve IPO or be acquired during periods of strong financial markets. Liquidity alternatives were greater during period two than period one, and greater during period one than period three.	External Environment Liquidity Alternatives	5.5.5
H34	Liquidity alternatives are related to financing. VC-backed ventures are more likely to achieve positive liquidity events than bootstrapped ventures.	Financing Liquidity Alternatives	5.5.5
H35	Liquidity alternatives are related to the separation agreement. A competitor to the parent corporation is less likely to pursue an acquisition of the new venture if the parent will accrue benefit from the sale.	Separation Agreement Liquidity Alternatives	5.5.5
H36	Liquidity alternatives are related to restrictions. Contractual restrictions, particularly regarding disposal of intellectual property, negatively impact a venture's alternatives for liquidity.	Restrictions Liquidity Alternatives	5.5.5
H37	Founder motivations are related to the external environment. During periods of strong financial markets, a founder has financial incentives to grow the new venture towards IPO.	External Environment Founder Motivations	5.5.6
H38	Founder motivations are related to financing and incubation. Founders of new ventures spinning out of corporate incubators with VC-financing were not required to invest personal funds in the new venture. The consequences of failure for those founders are lower.	Financing Incubation Founder Motivations	5.5.6
H39	Founder financial motivations are related to separation agreement. Founder ownership at liquidity is lower at corporate ventured spin-offs than independent new ventures. <i>This hypothesis is only weakly supported by the data.</i>	Separation Agreement Founder Motivations	5.5.6
H40	Access to technology is related to the separation agreement. The separation agreement provides the corporate ventured technology spin-off with ownership of, or access to, intellectual property controlled by the parent.	Separation Agreement Access to Technology	5.6.1
H41	Access to technology is related to the separation agreement. New ventures with parent ownership were transferred ownership of their intellectual property. New ventures with licensing agreements gained access to intellectual property owned by the parent.	Separation Agreement Access to Technology	5.6.1
H42	Access to capital is related to the external environment. The availability of capital during period two was greater than the availability of capital during period one, which was greater than the availability of capital during period three.	External Environment Access to Capital	5.6.2
H43	Access to capital is related to technology characteristics. Demand for capital varies with the resource-intensity of the innovation to be commercialized.	Technology Characteristics Access to Capital	5.6.2
H44	Access to capital is related to financing. VC-backed new ventures tend to be better financed than bootstrapped new ventures.	Financing Access to Capital	5.6.2
H45	Access to capital is not related to separation agreement. Investors do not systematically treat corporate ventured technology spin-offs either more favorably or less favorably than independent new ventures.	Separation Agreement Access to Capital	5.6.2
H46	Access to capital is related to restrictions. Contractual restrictions negatively impact a venture's access to risk capital.	Restrictions Access to Capital	5.6.2

#	Relationship	Categories	Ref
H47	Access to capital is related to liquidity alternatives. Constraints on a new venture's alternatives for liquidity negatively impact a venture's access to risk capital.	Liquidity Access to Capital	5.6.2
H48	The quality of advice from any stakeholder is related to the relevance of that stakeholder's knowledge and experience to the circumstances of the new venture.	Advice	5.6.3
H49	Advice is related to the external environment. During period two, VCs advised aggressive growth. During period three, VCs advised a focus on cost control, revenues, and profitability, sometimes demanding spending controls and layoffs.	External Environment Advice	5.6.3
H50	Access to advice is related to financing. VC investors provide advice to their investments.	Financing Advice	5.6.3
H51	Access to advice is related to the separation agreement. Stakeholders from the parent corporation provide advice to their investments.	Separation Agreement Advice	5.6.3
H52	Access to advice is related to incubation. Incubated ventures have greater access to advice from the parent during the incubation period.	Incubation Advice	5.6.3
H53	The availability of assets and services is related to incubation. Ventures in corporate incubators have greater access to assets and services than do ventures that are not incubated. Ventures in structured incubators have greater access to assets and services than do ventures in an informal incubator.	Incubation Assets and Services	5.6.4
H54	A new venture gains external legitimacy by securing endorsements, including investor endorsement (financing), parent endorsements (commercializing technology from the parent, technology transfer, technology licensing, customer relationships, branding) and market endorsements (high-profile customers, suppliers, partners, external directors).	Legitimacy	5.6.5
H55	Legitimacy is related to the external environment and incubation. Founders of corporate ventures during period one expended energy building entrepreneurial legitimacy within the parent corporation.	External Environment Incubation Legitimacy	5.6.5
H56	Legitimacy is related to technology characteristics. Sustaining technologies have greater external legitimacy than disruptive technologies.	Technology Characteristics Legitimacy	5.6.5
H57	Legitimacy is related to financing. VC-backing increases the legitimacy of a new venture.	Financing Legitimacy	5.6.5
H58	Legitimacy is related to separation agreement. New ventures that license technology have more parent endorsements than do independent ventures. Ventures with higher parent ownership have more parent endorsements than do ventures with lower parent ownership. <i>Legitimacy is related to endorsements (H54).</i>	Separation Agreement Legitimacy	5.6.5
H59	Customer relationships are related to external environment. Customer spending is higher during strong financial markets. Access to customers is greater when customer spending is higher. Access to customers is greater during period two than period one, and greater during period one than period three.	External Environment Customer Relationships	5.6.6
H60	Customer relationships are related to financing. VC-backed ventures have better access to customers.	Financing Customer Relationships	5.6.6
H61	Customer relationships are related to the separation agreement. Through support of the parent's sales organization, majority-controlled ventures have greater access to customers in the parent's value network. This relationship is more valuable to new ventures to sell a product or service into the parent's value network.	Separation Agreement Customer Relationships	5.6.6

#	Relationship	Categories	Ref
H62	Customer relationships are related to the separation agreement. A spin-off's relationship to the parent corporation can limit access to some customers. A venture with a separation agreement from the parent has reduced access to customers that compete with the parent.	Separation Agreement Customer Relationships	5.6.6
H63	Customer relationships are related to legitimacy. Ventures with greater external legitimacy have greater access to customers.	Legitimacy Customer Relationships	5.6.6
H64	Supplier relationships are related to technology characteristics. Improving access to suppliers is more significant for ventures commercializing resource-intensive technologies.	Technology Characteristics Supplier Relationships	5.6.7
H65	Supplier relationships are related to financing. VC-backed ventures have better access to suppliers and partners than do bootstrapped ventures.	Financing Supplier Relationships	5.6.7
H66	Supplier relationships are related to the separation agreement. Majority-controlled ventures can leverage the parent's existing supply agreements for better terms and pricing. This is more significant for ventures that seek to acquire inputs from suppliers of the parent corporation.	Separation Agreement Supplier Relationships	5.6.7
H67	Supplier relationships are related to legitimacy. Ventures with greater external legitimacy have greater access to suppliers.	Legitimacy Supplier Relationships	5.6.7
H68	The workforce supply is related to the external environment. Ventures founded during period three had access to a larger supply of talent than did ventures founded during periods one or two.	External Environment Workforce	5.6.8
H69	The workforce profile of a spin-off is related to the properties of the separation agreement. New ventures that are more closely related to the parent (higher parent ownership, licensing) have a workforce profile that more closely resembles the workforce profile of the parent. New ventures that are less closely related to the parent (lower parent ownership, no licensing) have a workforce profile that more closely resembles that of a start-up.	Separation Agreement Workforce	5.6.8

5.8 Comparing Practitioner Beliefs and Grounded Theory

This section compares practitioner beliefs (summarized in section 5.2) to the emergent grounded theory (summarized in section 5.7).

Practitioner beliefs were generally consistent with the emergent findings grounded in the data. There were no glaring contradictions, and many of the generalized relationships proposed by practitioners were similar to grounded hypotheses discovered through constant comparison. There were, however, a few significant differences.

As noted in section 2.2.1, there is much confusion among both researchers and practitioners regarding the specific usage of the term "spin-off". Practitioner beliefs reflect that ambiguity with a lack of precision. In particular, the categories distinguishing corporate

ventured technology spin-offs were not well understood. As a result, some firm attributes are attributed to whether a new venture is or is not a spin-off, rather than the causal factors discovered in the data. Many practitioners recognized the heterogeneity of the spin-off data set (proposition #1), but not necessarily the causal factors responsible for that diversity.

Some of the relationships proposed by practitioners were not discovered in the data. In particular, practitioner propositions regarding founder rewards, culture, workforce turnover, and the impact of a safety net are not part of the grounded theory. In some instances, the proposed categories did not emerge as main concerns of practitioners, and were not deemed sufficiently robust for a place in the grounded theory. In others, the relationships were not emergent from the data, implying that the proposed relationships are weak or non-existent. In others, the data that would be required was not within the scope of this study.

Some practitioner beliefs could inspire future research studies, especially studies employing complementary methods of hypothesis testing. In particular, propositions regarding cognitive bias, founder rewards, culture, and safety net would be interesting for further study.

6 Discussion of Results

This study has made three contributions to the body of knowledge on technology entrepreneurship. First, it has developed two useful theoretical constructs – the *decision environment* and the *resource environment*. Second, it has developed a grounded theory to account for differences in the decision and resource environments of corporate ventured technology spin-offs and other new ventures, drawing from interviews with fifteen practitioners, case studies of eight new ventures, and a survey of the salient management literature. Third, it has compared emergent findings with extant literature to extend or replicate existing theory and identify anomalies.

Key findings were summarized in section 1.5. The complete grounded theory of decision and resource environments was presented in section 5.7.

6.1 Validity

This section discusses the extent to which the grounded theory of this study accounts for the behavior of the data set (internal validity) and is generalizable to other new ventures outside of the data set (external validity).

Internal validity has been established through sound research methods (see section 4) and careful execution (see sections 4 and 5). The resulting theory accounts for most of the behavior in the data set. It is presented in a form that is parsimonious, testable, and logically coherent, consistent with Pfeffer's (1982) criteria of good management theory. It is also consistent with Glaser's (1998) criteria for judging good grounded theory – fit, workability, relevance, and modifiability.

External validity will be bounded by several factors, including the limited time frame of the study, the uniqueness of the parent organization, and the uniqueness of the geographical region. Each of these factors is addressed below.

The external environment during which a venture was founded has been shown to impact some elements of the decision and resource environment. The characteristics of that environment have been shown to change over time. New ventures founded during each of the three periods between 1992 and 2001 experienced different external environments, including

different market conditions, regional conditions, and conditions at the parent firm. The amplitude of the Internet technology boom (period 2) and the subsequent technology meltdown (period 3) were greater than other market cycles of recent history (Stiglitz, 2003). Other ventures that have spun-out before or will spin-out after the time interval of this study may experience a different external environment not fully described by any of these groups. With future work, it may be possible to discover new external environment groups (i.e. period 4) or to discover sub-categories that are more generalizable. These extensions, outside the scope of this study, would advance rather than invalidate this theory.

Nortel is similar in many regards to other large technology corporations. It has four attributes that may be atypical. First, Nortel is geographically specialized. It has a strong R&D center in the Ottawa area; most business development functions are headquartered elsewhere, often at U.S. locations. A founding team consisting entirely of Ottawa-based Nortel employees would be expected to reflect those strengths and weaknesses. One founder acknowledged that his founding team initially lacked sales and marketing experience, yet survived to overcome that weakness and achieve a successful liquidity event. Second, Nortel climbed higher and fell harder than most other technology companies during the Internet bubble and the subsequent technology meltdown (Bagnall, 2002). Third, Nortel's participation in a cross-licensing patent pool (see section 5.6.1) has implications on its strategy regarding the transfer of IP ownership. A parent corporation that did not belong to a cross-licensing pool may approach technology transfer differently. Fourth, Nortel elected not to invest additional funds in any of its spin-off ventures after they had spun-off (see section 5.4.4). Other parent corporations may have different policies regarding follow-on investment.

Ottawa is similar in many regards to other world-class regional technology clusters. According to Ghent-Mallet (2002), four of the five typical cluster elements were present during the formation of the Ottawa cluster – access to technology and technical know-how, availability of highly qualified people, visionary entrepreneurship, and networks and linkages. The fifth typical cluster element – access to local venture capital – is a relatively recent development that arrived in the region in the mid-1990s (see section 5.4.1). The Ottawa cluster does have some attributes that may be atypical. First, the historical development of the Ottawa cluster was

dominated by one particular large anchor firm – Nortel Networks (Ghent-Mallet, 2002). Second, compared to technology clusters in the United States, some investors believe that the Ottawa cluster has a greater shortage of experienced sales and marketing executives. See, for example, the recent discussions documented by Hammond (2003a, 2003b, 2003c). Some entrepreneurs in this study disagreed. According to one founder,

"Ottawa has many capable and experienced people. They may not have the same level of experience as the guys in the valley, but it's not that hard to acquire. What they need is mentoring and support and help from VCs. If VCs would allocate more resources to working with the management teams of fledgling start-ups, everyone could benefit."

One strength of this style of research is its extensibility. Future studies could extend this grounded theory by introducing new categories to account for variables that were controlled in this data set. New categories could account for new properties of the external environment, different characteristics of other parent firms, and different regional characteristics. Such extensions would broaden the external validity of the theory beyond the boundaries noted here.

6.2 Comparison to Extant Literature

The results of this study have several implications regarding the spin-off formation models reviewed in section 2.2.2. The agency spin-off formation models of Wiggins (1995), Anton & Yao (1995), Bankman & Gilson (1999), and Hellmann (2003) all model an entrepreneur's decision of whether to develop an idea internally within the parent corporation or externally as an independent new venture. Not one entrepreneur interviewed here reported any such decision. The six corporate ventures in this study were critically dependent on access to intellectual property owned by the parent; without access to that IP, these ventures would not have been viable. The two independent ventures were both founded by employees that had already been downsized by the parent; they had no opportunity to develop their venture internally.

One explanation for this discrepancy is that the underlying assumptions behind agency models may be more appropriate for regions such as Silicon Valley. Gilson (1999) concludes that California's restriction of post-employment non-competitive covenants encouraged employee mobility and allowed the Silicon Valley cluster to thrive. Hyde (1998) shows that California courts have an employee-friendly attitude regarding intellectual property protection.

These agency models may be less applicable to the Ottawa region of Canada where intellectual property protections are stronger.

The entrepreneurs in this study did cite both perceived limitations of the parent corporation and employee learning as incentives for the formation of their new ventures. The underlying assumptions of the organizational capability perspective and the employee learning perspective of spin-off formation would appear to be better aligned with the founding circumstances of the ventures in this study. As well, restructuring at the parent corporation was a factor in the formation of six of the new ventures in this study. Most formation models do not specifically account for the impetus of corporate restructuring.

Discrepancies between the assumptions of a formation model and the actual circumstances of new venture creation do not necessarily invalidate that theory. According to Friedman (1966), theory should not be judged on the realism of its assumptions, but only on its predictive power. Friedman further warns that a theory or its assumptions cannot possibly be thoroughly realistic; any attempt to move very far in achieving realism is certain to render a theory useless. Nonetheless, further efforts to categorize spin-off formation may provide insights into the circumstances under which a particular formation model is most appropriate (Christensen, Carlile & Sundahl, 2002).

The results of this study also have implications for the various spin-off classification frameworks published in the literature. The spin-off and corporate venturing terminology in use today is often ambiguous (see section 2.2.1). This grounded theory of decision and resource environments could form the basis of an attribute-based classification scheme of new venture formation. Any complete spin-off framework must account for the causal variables identified in this study, particularly the separation agreement from the parent corporation and the incubation environment.

Some spin-off definitions in the management literature would exclude new ventures that are majority-owned by the parent corporation. The grounded theory of this study treats ownership as one property of the separation agreement, and while it does indeed impact the decision and resource environments, majority-controlled spin-offs share many traits with minority-controlled spin-offs, and with spin-offs which license their technology from the parent.

Furthermore, the majority-controlled spin-offs in this study became minority-controlled spin-offs as the parent's ownership position was diluted by new investment.

Other frameworks would classify spin-offs according to the impetus of formation – either entrepreneurial (instigated by the founders) or restructuring (instigated by the parent). The ventures in this study are not easily classified into those categories, which do not account for differences in the decision and resource environments between new ventures. The impetus of formation would seem to impact the decision and resource environments only to the extent that it impacts the properties of the separation agreement and the incubation environment.

Extant frameworks do not adequately account for the "start-up spin-off" venture described in section 5.4.5. A "start-up spin-off" forms initially as an independent new venture, then subsequently negotiates a separation agreement with the parent that provides it with access to critical IP. Entrepreneurs founding a "start-up spin-off" make and execute on decisions in different decision and resource environments than founders of either corporate incubated spin-offs or independent start-ups with no incubation. This mode of formation may be more common during periods of restructuring when the energy of the parent corporation is focused on restructuring and cost control rather than investment opportunities in new businesses. Two examples of this formation mode were discovered in this study.

6.3 Implications for Practitioners

The results of this study have practical implications for entrepreneurs, corporate executives, venture capital investors, and public policy makers.

Entrepreneurs can use this model to better understand how the founding circumstances of a new venture have a lasting impact on their decision and resource environments. Some factors, such as the external environment, are outside of founder control. Other factors, such as the separation agreement and the incubation environment, are negotiated between the founders and the parent. Based on this model, the founding entrepreneurs can negotiate towards the separation agreement and incubation environment that is most likely to provide the sort of decision and resource environments that they deem likely to make their venture successful. It may also help an entrepreneurially minded employee decide whether to pursue an independent new venture or a corporate spin-off.

Corporate executives can use this model to predict the impact of their actions on the characteristics of a spin-off, and use this understanding to guide corporate policy decisions on corporate venturing.

Venture capital investors can use this model to evaluate potential investments and to guide their decisions of when and how to become involved with decisions at their existing investments.

Public policy makers can use this model to assess policy alternatives that would encourage or discourage corporate venturing, spin-off formation, and intellectual property protection. It complements ongoing research on the formation of regional technology clusters.

6.4 Opportunities for Future Research

Section 5.7 summarizes a list of testable hypotheses that were emergent from case study data and interviews with practitioner respondents. These hypotheses should be tested independently with quantitative research methods.

From the perspective of the Christensen et al. (2002) theory-building model, theory regarding corporate ventured technology spin-offs would appear to be in a pre-paradigmatic theory-building cycle. The application of research methods appropriate for "normal" science (Kuhn, 1962) may be premature for this research area.

An intermediate step towards a management paradigm would be the development of a useful and robust spin-off and corporate venturing classification framework. The literature survey has shown that corporate venturing and spin-off research address some of the same phenomena from different perspectives. Any complete theory must account for the findings of both research streams and the core categories discovered in this study – the *separation agreement* with the parent and the characteristics of the *incubation* environment.

Future inductive qualitative studies of other parent firms, other geographical regions, and other time periods could extend this work into a general theory of decision and resource environments of new ventures. Such work would continue to employ theoretical sampling to seek anomalies with extant theory. In time, the attribute-based categories described here could evolve to a more robust circumstance-based categorization scheme that would appear intuitively

simple to practitioners, and better reflect their main concerns. This research agenda is in-line with the Christensen et al. (2002) theory-building model.

Some spin-off founders cited frustration with one or more aspects of the spin-off process. Areas of tension included the slow pace of decision-making, the time and complexity of negotiating the separation agreement, and the contribution and relevance of parent representation on the board of directors of a new venture. Executives were likewise concerned about the most effective deployment of scarce corporate resources, and the protection of corporate interests including intellectual property and brand value. Research into improving the corporate venturing spin-off process should continue.

Corporate venturing is controversial, and practitioner opinions on its efficacy vary widely. In the words of one seasoned founder:

"I believe that a real business needs to be built in the real world, not in the womb of a parent organization. You need to live this. You can't just study it. You can't learn it from a book.

The support and advice of our VC investors, and mentorship from two senior executives with solid business experience was immensely valuable. However, the advice of career corporate executives and inexperienced venture managers was only marginally helpful for growing a new business."

Contrast that view with the remarks of Silicon Valley consultants Mason & Rohner (2002, p. 3):

"Venturing is an essential tool for every company that intends to be a leader in a world that is increasingly technology-driven."

The relevant research question is not whether corporate venturing is good or bad. There are well-documented cases of both successful and unsuccessful corporate ventured spin-offs. Rather, there is a need to understand the circumstances under which a corporate ventured spin-off provides the most advantage to both the parent firm and the entrepreneur, and the circumstances under which a different approach may be more appropriate. The Chesbrough (2002) investment framework addresses the related topic of corporate venture capital from the perspective of the corporate investor, linking investment objective to the degree of linkage of organizational capabilities. A complete view of corporate venturing may take a similar form, extended to address the main concerns of all practitioners – both entrepreneurs and corporate

executives.

The management literature shows that many corporate venturing programs have been very short-lived. Nortel began to shut down its corporate venturing program in the last months of the technology boom before the dot-com collapse of April 2000. Nonetheless, the program had produced three external spin-offs, one IP license to an outside firm, and five spin-ins back to lines of business (Colarelli O'Connor & Maslyn, 2002). The parent also spun-out two other ventures in 1998 independently of the CV program. Is it possible to create an enduring corporate venturing program that can weather the market cycles, corporate policy changes, and turnover in executive management? Christensen et al. (2002) provides a possible explanation for the waxing and waning popularity of corporate venturing and corporate venturing programs:

"One reason why platitudes and fads in management come and go with predictability is that typically they are not grounded in a robust categorization scheme. They are espoused as one-size-fits-all statements of cause and effect. Hence, managers try the fad out because it sounds good, and then discard it when they encounter circumstances in which the recommended actions do not yield the predicted results. Their conclusion most often is, "It doesn't work" – when the reality often is that it works well in some (as yet undefined) circumstances, but not in others."

On the other hand, is an enduring corporate venturing program even useful or desirable? The Hellmann (2003) spin-off formation model predicts that corporations will create internal venturing programs in response to growing numbers of departing employees, and discontinue those programs when economic conditions change. Perhaps the current state of affairs is actually the most efficient, where a corporation enters into a short experiment with corporate venturing when it aligns with corporate strategy then exits that initiative when it is longer useful. These answers will require more high-impact research, and a robust categorization framework that addresses the circumstances and main concerns of both entrepreneurs and corporate executives.

7 References

- Abernathy, W., Clark, K., & Kantrow, A. (1983), *Industrial Renaissance: Producing a Competitive Future for America*, Basic Books.
- Abernathy, W., & J. Utterback (1978), "Patterns of Industrial Innovation," *Technology Review*, 80: 40-47.
- Agarwal, R., Echambadi, R., Franco, A.M., & Sarkar, M.B. (2002), "Knowledge Transfer Through Congenital Learning: Spin-out Generation, Growth and Survival", working paper.
- Alcalay, R. (2003), *The New Economy: What it is, How it Happened, and Why it is Likely to Last*, New York: Farrar, Strauss, and Giroux.
- Aldrich, H.E. & Fiol, C.M. (1994), "Fools Rush In – The Institutional Context of Industry Creation", *Academy of Management Review*, October.
- Andrews, K. (1971), *The Concept of Corporate Strategy*, Dow Jones-Irwin.
- Annema, A., Fallon, W., & Goedhart, M. (2002), "When Carve-outs Make Sense", *The McKinsey Quarterly*.
- Anslinger, P., Bonini, S., & Patsalos-Fox, M. (2000), "Doing the Spin-Out", *The McKinsey Quarterly*, Number 1, pp. 98-105.
- Anslinger, P., Carey, D., Fink, K. & Gagnon, C. (1997), "Equity Carve-Outs: A new spin on the corporate structure", *The McKinsey Quarterly*, Number 1, pp. 165-172.
- Anslinger, P., Klepper, S., & Subramaniam, S. (1999), "Breaking Up is Good to Do", *The McKinsey Quarterly*, Number 1, pp. 16-27.
- Anton, J. & Yao, D. (1995), "Start-ups, Spin-offs, and Internal Projects", *Journal of Law, Economics, and Organization*, V11 N2.
- Athey, S. & Stern, S. (1997), "An Empirical Framework for Testing Theories About Complementarity in Organizational Design", Unpublished working paper, MIT. Available on-line at: <http://www.stanford.edu/~athey/testcomp0498.pdf>
- Autio, E. (1997), "New Technology-based firms in innovation networks: sympathetic and generative impacts", *Research Policy* 26, 263-281.
- Bagnall, J. (2002), "House of Glass: Nortel's Shattered Legacy: A Special Five-Part Series", *The Ottawa Citizen*, Southam Publications, November 7-11.
- Bankman, J. & Gilson, R.J. (1999), "Why Start-ups?", *Stanford Law Review*, 51, pp. 289-308.
- Barney, J. (1991), "Firm Resources and Sustained Competitive Advantage", *Journal of Management*, 17: 99-120.
- Baron, J., Burton, M.D., & Hannan, T. (1999), "Engineering Bureaucracy: The Genesis of Formal Policies, Positions, and Structures in High-Technology Firms", *Journal of Law Economics and Organization* 15 (1): 1-41.

- Barry, D. (2000), "Corporate Incubators Seen Aiding Search for Newest Technologies", *The Corporate Venturing Report*, October, pp. 1-19.
- Bessant, J. (1998), "Developing Continuous Improvement Capability", *International Journal of Innovation Management Vol 2 No 4*.
- Bhide, A.V. (2000), *The Origin and Evolution of New Business*, Oxford University Press.
- Bhide, A.V. (2002), "Taking Care: How Mechanisms to Control Mistakes Affect Investment Decisions", Columbia Business School, in press, revised August 2002. Available at: http://www.gsb.columbia.edu/faculty/abhide/bhide_taking_care.pdf
- Block, Z. & MacMillan, I. (1993), *Corporate Venturing: Creating New Businesses Within the Firm*, Harvard Business School Press.
- Boeker, W. (1988), "Organizational Origins: Entrepreneurial and Environmental Imprinting at the Time of Founding", *Ecological Models of Organizations*, Ballinger Publishing, pp. 33-51.
- Boeker, W. (1989), "Strategic Change: The Effects of Founding and History", *Academy of Management Journal*, 32 (3): 489-515.
- Brav, A. & Gompers, P.A. (1997), "Myth or Reality? The Long-Run Underperformance of Initial Public Offerings: Evidence from Venture and Nonventure Capital-backed Companies", *Journal of Finance*, Vol. 52, no. 5, pp. 1791-1821
- Brittain, J.W., & Freeman, J. (1986), "Entrepreneurship in the Semiconductor Industry", unpublished paper presented at the Academy of Management meetings.
- Brown, S. & Eisenhardt, K. (1995), "Product Development: Past Research, Present Findings, and Future Directions", *Academy of Management Review* 20 (2), pp. 343-378.
- Brown, S. & Eisenhardt, K. (1997), "The Art of Continuous Change: Linking Complexity Theory and Time-paced Evolution in Relentlessly Shifting Organizations", *Administrative Science Quarterly*.
- Burton, M.D., Sorensen, J.B., & Beckman, C.M. (2001), "Coming from Good Stock: Career Histories and New Venture Formation", Forthcoming in *Research in the Sociology of Organizations*. Available on-line at: <http://web.mit.edu/sorensen/www/GoodStockJuly2001.pdf>
- Cable, D.M. & Shane, S. (1997), "A Prisoner's Dilemma Approach to Entrepreneur-Venture Capitalist Relationships", *Academy of Management Review*, Vol. 22. No. 1, 1997. pp. 142-176.
- Callahan, J. & Muegge, S. (2003), "Venture Capital's Role in Innovation: Issues, Research, and Stakeholder Interests", in L.V. Shavinina (editor), *The International Handbook on Innovation*, Elsevier Press.
- Callahan, J., & Sharp, J. (1985), "Entrepreneurs and Venture Capitalists: Differences in Growth Objectives", School of Business, Carleton University.
- Chesbrough, H. (2000). "Designing Corporate Ventures in the Shadow of Private Venture

- Capital." *California Management Review*, Spring 2000, pp. 31-49.
- Chesbrough, H. (2002), "Making Sense of Corporate Venture Capital," by Henry Chesbrough, *Harvard Business Review*, March.
- Chesbrough, H. & Rosenbloom, R.S. (2002), "The Role of the Business Model in Capturing Value from Innovation: Evidence from Xerox Corporation's Technology Spin-off Companies", *Industrial and Corporate Change* 11: 529-555.
- Chesbrough, H. & Smith (2000), "Chasing Economies of Scope: Xerox's Management of Its Technology Spinoff Organizations", unpublished manuscript. Available on-line at: <http://www.people.hbs.edu/hchesbrough/spinoff.pdf>
- Chesbrough, H., & Socolof, S. (2000), "Commercializing New Ventures from Bell Labs Technology: The Design and Experience of Lucent's New Ventures Group", *Research-Technology Management*, pp. 1-11.
- Christensen, C. (1993), "The Rigid Disk Drive Industry: A History of Commercial and Technological Turbulence", *Business History Review*, Winter, 531-588.
- Christensen, C. (1997), *The Innovator's Dilemma*, Harvard Business School Press.
- Christensen, C., Carlile, P., & Sundahl, P. (2002), "The Process of Theory-Building", Working Paper 02-016, <http://www.innosight.com>.
- Christensen, C. & Rosenbloom, R.S. (1995), "Explaining the attacker's advantage: technological paradigms, organizational dynamics, and the value network", *Research Policy* 24: 233-257.
- Cohen, W. & Levinthal, D. (1990), "Absorptive Capacity: A New Perspective on Learning and Innovation", *Administrative Science Quarterly*, 35: 128-152.
- Colarelli O'Connor, G., & Maslyn (2002), *Nortel Networks Business Ventures Group*, Case Study 102-C02, Babson College Case Development Center.
- Colley, J.L., Doyle, J.L., Logan, G.W., & Stettinius, W. (2003), *Corporate Governance*, McGraw Hill.
- Cooper, A.C. (1971), *The Founding of Technologically-Based Firms*, The Center for Venture Management.
- Cooper, A.C. (1985), "The Role of Incubator Organizations in the Founding of Growth-Oriented Firms", *Journal of Business Venturing*, 1, pp. 75-86.
- Cooper, A.C. (1986), "Entrepreneurship and High Technology", in D.L. Sexton and R.W. Smilor (editors), *The Art and Science of Entrepreneurship*, Cambridge, MA: Ballinger Publishing, pp. 153-167.
- Cumming, D. & MacIntosh, J. (2002), "Venture Capital Exits in Canada and the United States", 2002 Babson Conference on Entrepreneurship.
- Day, J., & Wendler, J. (1988), "The New Economics of Organization", *The McKinsey Quarterly*, Number 1, pp. 4-17.

- Dick, B. (2000), "Grounded Theory: A Thumbnail Sketch", [on line] Available at <http://scu.edu.au/schools/gcm/ar/arp/grounded.html>
- Dixit, A.K., & Skeath, S. (1999), *Games of Strategy*, New York: Yorkton.
- Dorfman, N.S., (1983), "Route 128: The Development of a Regional High Technology Economy", *Research Policy*, Vol. 12, No. 6, pp. 299-316.
- Dosi, G. (1982), "Technological Paradigms and Technological Trajectories", *Research Policy* (11), 147-162.
- Doyle, D. (2002), *The Family Tree of Ottawa-Gatineau High Technology Companies*, DoyleTech Corporation: Ottawa Canada.
- Dyck, B. (1997), "Exploring Organizational Family Trees", *Journal of Management Inquiry*, 6(3), pp. 222-233.
- Dyck, B. (2001), "An Exploratory Study of Multi-Organizational Clans: A Look at Population of Congregations", In Alex Z. Kondra (Ed.), *Proceedings of Organizational Theory Division*, 22(22): 24-34. Administrative Sciences Association of Canada..
- Eisenhardt, K. (1989), "Building Theories from Case Study Research", *Academy of Management Review*, Vol 14, No 4. 532-550.
- Fast, N. (1978), *The Rise and Fall of Corporate New Venture Divisions*, Ann Arbor, MI: UMI Research Press.
- Fenn, Liang, & Prowse (1997), "The Role of Angel Investors and VCs in Financing High-Tech Start-Ups", Board of Governors of the Federal Reserve System.
- Foddy, W. (1993), *Constructing Questions for Interviews and Questionnaires: Theory and Practice in Social Research*, Cambridge University Press.
- Franco, A.M., & Filson, D. (2000), "Knowledge Diffusion through Employee Mobility", Federal Reserve Bank of Minneapolis, Staff Report, 272.
- Friedman, M. (1966), "The Methodology of Positive Economics", in *Essays In Positive Economics*, University of Chicago Press, pp. 3-43.
- Garvin, D.A. (1983), "Spin-offs and the New Firm Formation Process", *California Management Review*, January, pp. 3-20.
- Ghent-Mallet, J. (2002), *Silicon Valley North: The Formation of the Ottawa Innovation Cluster*, Information Technology Association of Canada.
- Gilson, R.J. (1999), "The Legal Infrastructure of High Technology Industrial Districts: Silicon Valley, Route 128, and Covenants Not to Compete", *New York University Law Review* 74, pp. 575-629.
- Glaser, B. (1978), *Theoretical Sensitivity: Advances in the Methodology of Grounded Theory*, Sociology Press.
- Glaser, B. (1992), *Basics of Grounded Theory Analysis: Emergence vs. Forcing*, Sociology Press.

- Glaser, B. (1998), *Doing Grounded Theory: Issues and Discussions*, Sociology Press.
- Glaser, B. & Strauss, A. (1967), *The Discovery of Grounded Theory: Strategies for Qualitative Research*, Aldine de Gruyter.
- Goel, V. & Pirolli, P. (1992), "The Structure of Design Problem Spaces", *Cognitive Science*, 16.
- Gompers, P.A. & Lerner, J. (1999a), *The Venture Capital Cycle*, MIT Press.
- Gompers, P.A. & Lerner, J. (1999b), "The Determinants of Corporate Venture Capital Success: Organizational Structure, Incentives, and Complementarities", in Randall Morck, editor, *Concentrated Corporate Ownership*, University of Chicago Press for the National Bureau of Economic Research.
- Gompers, P.A. & Lerner, J. (2001a), "The Venture Capital Revolution", *Journal of Economic Perspectives* 15, pp. 145-168. Available on-line at:
<http://fletcher.tufts.edu/staff/mkahn/Venture.pdf>
- Gompers, P.A. & Lerner, J. (2001b), *The Money of Invention*, Cambridge, MA: Harvard Business School Press.
- Grindley, P. & Teece, D.J., (1997), "Managing Intellectual Capital: Licensing and Cross-Licensing in Semiconductors and Electronics", *California Management Review* 39 (2), pp. 1-34.
- Hamel, G. (1999), "Bringing Silicon Valley Inside", *Harvard Business Review*, September, pp. 71-84.
- Hamel, G. (2000), "Reinvent Your Company", *Fortune*, Monday June 12.
- Hannan, M. & Freeman, J. (1989), *Organizational ecology*, Cambridge: Harvard University Press.
- Hansen, Chesbrough, H., Nohria, Sull (2000), "Networked Incubators: Hothouses for the New Economy", *Harvard Business Review* 78 Sep-Oct, pp. 74-84.
- Hellmann, T. (2003), "When Do Employees Become Entrepreneurs?", Stanford University Working Paper. Available at <http://faculty-gsb.stanford.edu/hellman/index.htm>
- Hellmann, T. & Puri, M. (2000), "The Interaction Between Product Market and Financial Strategy: The Role of Venture Capital", *Review of Financial Studies*, pp. 959-984.
- Hellmann, T. & Puri, M. (2002), "Venture Capital and the Professionalization of Start-Up Firms: Empirical Evidence", *Journal of Finance*, 57 (1): 169-197.
- Henderson, R. & Clark, K. (1990), "Architectural Innovation: The Reconfiguration of Existing Product Technologies and the Failure of Established Firms", *Administrative Science Quarterly*, 35: 9-30.
- Hitt, M., & Ireland, D. (1986), "Relationships Among Corporate Level Distinctive Competencies, Diversification Strategy, Corporate Strategy and Performance", *Journal of Management Studies*, 23: 401-416.

- Hsu, D. (2000), "Do Venture Capitalists Affect Commercialization Strategies at Start-ups?", MIT IPC Working Paper 00-009. Available at: http://web.mit.edu/ipc/www/00-009_Hsu_VC.pdf
- Hunt, B. & Lerner, J. (1995), "Xerox Technology Ventures: March 1995", Harvard Business School case no. 9-295-127 (and teaching note no. 9-298-152).
- Hunter, D. (2002), *The Bubble and the Bear: How Nortel Burst the Canadian Dream*, Doubleday Canada.
- Hyde, A. (1998), "Silicon Valley's High-Velocity Labor Market", *Journal of Applied Corporate Finance*, 11 (2), pp. 28-37.
- Hyland, J. (2001), "Using VC Experience to Create Business Value", from Erin J. Kelly, editor, *From the Trenches : Strategies from Industry Leaders on the New E-economy*.
- Jick, T.D. (1979), "Mixing qualitative and quantitative methods: Triangulation in Action", *Administrative Science Quarterly* 24, pp. 602-11.
- Kaplan, S. & Stromberg, P. (2000a), "Financial Contracting Theory Meets the Real World: An Empirical Analysis of Venture Capital Contracts", National Bureau of Economic Research working paper no. 7660.
- Kaplan, S. & Stromberg, P. (2000b), "How do Venture Capitalists Choose and Manage their Investments?", University of Chicago working paper.
- Kaplan, S. & Stromberg, P. (2001), "Venture Capitalists As Principals: Contracting, Screening, and Monitoring", National Bureau of Economic Research working paper no. 8202.
- Kazanjian, R. (1988), "Relation of dominant problems to the stages of growth in technology-based new venture", *Academy of Management Journal* 31, 257-279.
- Kazanjian, R. & Drazin, R. (1989), "An empirical test of a stage of growth progression model", *Management Science* 35, 1489-1503
- Klepper, S. (2001), "Employee Startups in High-Tech Industries", *Industrial and Corporate Change*, 10:639-674.
- Klepper, S. & Sleeper, S., (2002), "Entry by Spinoffs", Unpublished working Paper, February.
- Kuhn, T. (1962), *The Structure of Scientific Revolutions*, Chicago: The University of Chicago Press.
- Lieber, R. (2000), "Startups – The 'Inside' Stories", *Fast Company* 32 (March), p. 284.
- Leifer, R., McDermott, C., O'Connor, G., Peters, L., Rice, M., & Veryzer, R. (2001), *Radical Innovation: How Mature Companies can Outsmart Upstarts*, Harvard Business School Press.
- Lerner, J. (1995), "Venture Capitalists and the Oversight of Private Firms", *Journal of Finance* 50, pp. 301-318.
- Lindholm, A. (1994), *The Economics of technology-related ownership changes: a Study of*

- Innovativeness and Growth Through Acquisitions and Spin-offs*, Doctoral dissertation. Department of Industrial Management and Economics, Chalmers University of Technology, Gothenburg, Sweden.
- Lindholm Dahlstrand A. (1997). Growth and inventiveness in technology-based spin-off firms. *Research Policy* 26, 331-344.
- Lindholm Dahlstrand A. (2001), "Entrepreneurial origin and spin-off performance: A Comparison between Corporate and University Spin-offs", published in Moncada-Paterno-Castello, P., Tubke, A., Miede, R., and Yaquero, T.B. (Eds), "Corporate and Research-based Spin-offs: Drivers for Knowledge-based Innovation and Entrepreneurship", *European Commission, IPTS Technical Report Series*. EUR 19903 EN, pp 43-66.
- MacDonald, L. (2000), *Nortel Networks: How Innovation and Vision Created a Network Giant*, Toronto: John Wiley & Sons Canada.
- Markham, S.K. & Griffin, A. (1998), "The Breakfast of Champions: Associations Between Champions and Product Development Environments, Practices, and Performance", *Journal of Product Innovation Management* 15, pp. 436-454.
- Mason, H. & Rohner, T. (2002), *The Venture Imperative: A New Model for Corporate Innovation*, Harvard Business School Press.
- Meggison, W. & Weiss, K. (1991), "Venture Capital Certification in Initial Public Offerings", *Journal of Finance* 46, pp. 879-893.
- Miles, M. & Huberman, M. (1994), *Qualitative Data Analysis: An Expanded Sourcebook, 2nd Edition*, Sage Publications.
- Montgomery, C.A. & Kaufman, R. (2003), "The Board's Missing Link", *Harvard Business Review* (March).
- Moore, G. & Davis, K. (2000), "Learning the Silicon Valley Way", Stanford Institute for Economic Policy Research Discussion Paper No. 00-45. Available at: http://siepr.stanford.edu/conferences/silicon_papers/moore.pdf
- Nelson, R. & Winter, S. (1982), *An Evolutionary Theory of Economic Change*, The Belknap Press of Harvard University Press, Cambridge, MA.
- Nesheim, J.L. (2000), *High-Tech Start-Up*, Simon and Schuster.
- Newell, A. & Simon, H.A. (1972) *Human Problem Solving*. Englewood Cliffs, NJ: Prentice Hall.
- Nortel Networks Corporation (2003), Annual and Quarterly Reports, 1993-2003
- Parhankangas, A. (1999), "Disintegration of Technological Competencies: An Empirical Study of Divestments Through Spin-Off Arrangements", Unpublished doctoral dissertation, Helsinki University of Technology.
- Parhankangas, A. & Arenius, P. (2003), "From a corporate venture to an independent company: a base for a taxonomy for corporate spin-off firms", *Research Policy* 32, p. 463-481.

- Partington, D. (2000), "Building Grounded Theories of Management Action", *British Journal of Management*, Vol. 11, 91-102.
- Pillieci, V. (2001), "Ottawa: Venture Capital of Canada", *The Ottawa Citizen*, Tuesday May 14, p. A1.
- Penrose, E.T. (1959), *The Theory of the Growth of the Firm*, New York: Wiley.
- Pfeffer, J. (1982), *Organizations and Organization Theory*, Marshfield, MA Pitman.
- Pfeffer, J. (1992), *Managing with Power: Politics and Influence in Organizations*, Boston: Harvard Business School Press.
- Pfeffer, J. & Salancik, G.R. (1978), *The External Control of Organizations: A Resource Dependence Perspective*, Harper & Row.
- Porter, M. (1985), *Competitive Advantage: Creating and Sustaining Superior Performance*, New York: The Free Press.
- Porter, M. (1998), "Clusters and the New Economics of Competition", *Harvard Business Review* (November-December).
- Porter, M. (2000), "Location, Competition, and Economic Development: Local Clusters in a Global Economy", *Economic Development Quarterly* 14 (1).
- Porter, M. & Stern, S. (2001), "Innovation: Location Matters", *MIT Sloan Management Review* 42 (4).
- Prahalad, C.K. & Betties, R.A. (1986), "The Dominant Logic: A New Linkage Between Diversity and Performance", *Strategic Management Journal*, Vol.7:485-511, Nov/Dec.
- PricewaterhouseCoopers/Venture Economics/National Venture Capital Association (2003), 2002 MoneyTree Survey. Available at: <http://www.pwcmoneytree.com>
- Richards, S. (2001), *Inside Business Incubators and Corporate Ventures*, John Wiley and Sons.
- Rind, K. (1981), "The Role of Venture Capital in Corporate Development", *Strategic Management Journal*, 2, 169-180.
- Roberts, E.B. (1980), "New Ventures for Corporate Growth", *Harvard Business Review* 58 Issue 4, pp. 134-142.
- Roberts, E.B. (1991), *Entrepreneurs in High Technology*, Oxford University Press.
- Rosenbloom, R.S., & Christensen, C.M. (1994), "Technological Discontinuities, Organizational Capabilities, and Strategic Commitments", *Industrial and Corporate Change* 3, 655-685.
- Sahlman, W. (1992), "Insights from the American Venture Capital Organization", Harvard Business School working paper #92-047.
- Saxenian, A. (1994), *Regional Advantage: Culture and Competition in Silicon Valley and Route 128*, Cambridge, MA: Harvard University Press.

- Schon, D.A. (1963), "Champions for Radical New Inventions", *Harvard Business Review*, March-April, pp. 77-86.
- Schoonhoven, C.B. & Eisenhardt, K.M. (1996), "Effects of Founding Conditions on the Creation of Manufacturing Alliances in Semiconductor Ventures", pp. 365-400, in *Strategic Integration*, eds. H. Thomas and D. O'Neal, John Wiley & Sons Ltd.
- Seabright, M., Leventhal, D., & Fichman, M. (1992), "Role of individual attachments in the dissolution of inter-organizational relationships", *Academy of Management Journal* 35, 122-160.
- Segaller, S. (1998), *Nerds 2.0.1: A Brief History of the Internet*, New York: TV Books.
- Shane, S. & Stuart, T. (2002), "Organizational Endowments and the Performance of University Start-ups", *Management Science*, Vol. 48, No. 1, pp. 154-170.
- Shapiro, C. (2001), "Navigating the Patent Thicket: Cross Licensees, Patent Pools, and Standard-Setting", *Innovation Policy and the Economy*, eds. J.L. Adam Jaffe and S. Stern, MIT Press, pp. 1-32.
- Shiller, R. (2000), *Irrational Exuberance*, Princeton: Princeton University Press.
- Siegel, R., Siegel, E., & MacMillan, I. (1988), "Corporate Venture Capitalists: Autonomy Obstacles and Performance", *Journal of Business Venturing*, 313, 233-247.
- Smi, L.W. (2000), "Project Clarity Through Stakeholder Analysis", *CrossTalk*, December
- Sonnenfeld, J. (2002), "What Makes Great Boards Great", *Harvard Business Review*, September.
- Stanworth, J., Stanworth, C., Granger, B. & Blyth, S. (1989), "Who Becomes an Entrepreneur?", *International Small Business Journal*, Vol. 8, 1, p.11-22.
- Stiglitz, J.E. (2003), *The Roaring Nineties: A New History of the World's Most Prosperous Decade*, New York: Norton.
- Stinchcombe, A. (1965), "Social Structure and Organizations", *Handbook of Organizations*, edited by J. March, Chicago, Rand McNally.
- Strauss, A.L., & Corbin, J.M. (1990), *Basics of Qualitative Research: Grounded Theory Procedures and Techniques*, Sage.
- Teece, D. (1988), "Technological change and the nature of the firm" in Dosi, G, Freeman, C, Nelson, R, Silverberg, G and Soete, L. (Eds). *Technical Change and Economic Theory*. Pinter. pp. 256-281.
- Thompson, R. (2002), "Bright lights amid high-tech gloom: Nortel JDS suffer but Ottawa has 200 start-ups", *Financial Post* (October 25).
- Thompson, A.A., & Strickland, A.J. (1983), *Strategy Formulation and Implementation*, Dallas: Business Publications.
- Tübke, A.(2001), "Success Factors of Corporate Spin-Offs", unpublished doctoral dissertation, Department of Industrial Organisation and Business Administration, University of Seville.

- Tübke, A.(2003), "Success Factors of Corporate Spin-Offs", Kluwer (forthcoming).
- Tübke, A., Álvarez de Toledo-Saavedra, P. & Galán-González, J.L. (2003), "Towards a First Spin-Off Typology and a New Concept for Spin-Off Research", *International Journal of Technology Transfer and Commercialization*.
- Tübke, A. & Empson, T. (2001), "Companies as Incubators ", *International Journal of Entrepreneurship and Innovation*, pp. 257-264.
- Tushman, M. & Anderson, P. (1986), "Technological Discontinuities and Organization Environments", *Administrative Science Quarterly*. 31: 439-465.
- Tushman, M. & O'Reilly, C. (1997), *Winning Through Innovation: A Practical Guide to Leading Organization Change and Renewal*, Harvard Business School Press.
- Utterback, J. (1994) *Mastering the Dynamics of Innovation*, Cambridge, MA:Harvard Business School Press.
- Von Hippel, E. (1977), "Successful and Failing Internal Corporate Ventures: An Empirical Analysis", *Industrial Marketing Management*, 6, 163-174.
- Walsh, S.T., Kirchoff, B.A., & Boylan, R.L. (1996), "Founder Backgrounds and Entrepreneurial Success: Implications for Core Competence Strategy Application to New Ventures", *Frontiers of Entrepreneurship Research*, Babson College: Wellesley, MA, pp. 146-154.
- Wernerfelt, B. (1984), "A Resource Based View of the Firm", *Strategic Management Journal*, 5:171-180.
- Wernerfelt, B. (1989), "From Critical Resources to Corporate Strategy", *Journal of General Management*, 14: 4-12.
- Weick, K.E.(1995), *Sensemaking in Organizations*, Sage.
- Wheelwright, S.C. & Clark, K.B. (1992), *Revolutionizing Product Development*, New York: The Free Press.
- Wiggins, S.N. (1995), "Entrepreneurial Enterprises, Endogenous Ownership, and the Limits to Firm Size", *Economic Inquiry*, 33, pp. 54-69.
- Wright, R. (1997) "Tangible integration versus intellectual codification skills: a comparison of learning processes in developing logic and memory semiconductors" in R. Sanchez and A. Heene (editors), *Strategic Learning and Knowledge Management*. Wiley, New York, pp. 83-100.
- Yin, Robert K. (1989), *Case Study Research: Design and Methods, Revised Edition*, Sage Press.
- Yost, M. (1994), "The State of Corporate Venturing: The Number of Active Programs Levels Off as Corporations Complete Shifts Back to Core Businesses", *Corporate Venturing*.
- Zider, B. (1998), "How Venture Capital Works", *Harvard Business Review*, November/December.